

Table of Contents

	DROP-IN COMPONENTS 10-31
	FLEXVENT™ SLIDE-IN 32-33
	SINKS 34-37
	DISPENSERS AND ORGANIZERS 38-41
	BREATH GUARDS 42-45
	LIGHT AND HEAT STRIPS, HEATED SHELVES 46-50
	DISPLAY CASES 51
	SERVUE™ TOUCHLESS SLIDE-IN 52-53
	INTRODUCTION TO SERVING SYSTEMS 54-57
	6-SERIES – <i>Front- and Back-of-House</i> 58, 61-69, 87-88
	4-SERIES – <i>Front- and Back-of-House</i> 59, 70-77, 89-92
	DOWNDRAFT 78-79
	2-SERIES – <i>Front- and Back-of-House</i> 59, 80-86, 93-96
	INDEX 97-101

SYMBOL LEGEND



Denotes items manufactured at one of our U.S. facilities



Denotes NSF-certified items



Denotes new item



International models



Denotes item with limited or extended warranty



Denotes product approvals by the respective organizations

WARRANTY POLICY

To view our complete warranty policy, please visit vollrathfoodservice.com/warranty.

Note: In the interest of continued product improvement, Vollrath reserves the right to change specifications without notice. Prices and availability are also subject to change without notice.

Dimensions listed in this catalog are approximate and may vary. Contact your Vollrath representative for specific drawing details.

DISCOVER MORE

Learn at Vollrath University



Vollrath University is the industry's best-in-class training resource for foodservice professionals. Whether it's at our world-class on-site training facility or online, Vollrath University can help you increase efficiency, drive profitability, and kindle inspiration, no matter what your industry role. Take advantage of Vollrath University, and arm yourself with everything you need to elevate your offering.



ON-SITE

- 13,000-square-foot world-class training facility
- Hands-on workstations
- Customizable training programs
- Manufacturing facility tours

ONLINE

- Helpful guides and reference materials
- Informational training videos
- Product tutorials
- Culinary support and recipes



Vollrath University

Opened in 2010, Vollrath University training facility is located on the grounds of Vollrath Corporate Headquarters in Sheboygan, Wisconsin. This beautiful 13,000-square-foot training area is where you will enjoy hands-on product experience in our fully functional commercial kitchen and top-notch instruction in our comfortable and spacious classroom.

DISCOVER MORE

Vollrath Online Tools



Vollrath offers convenient online access to a wealth of resources, including product information, recipes, user guides, new product email alerts, and more at vollrathfoodservice.com.

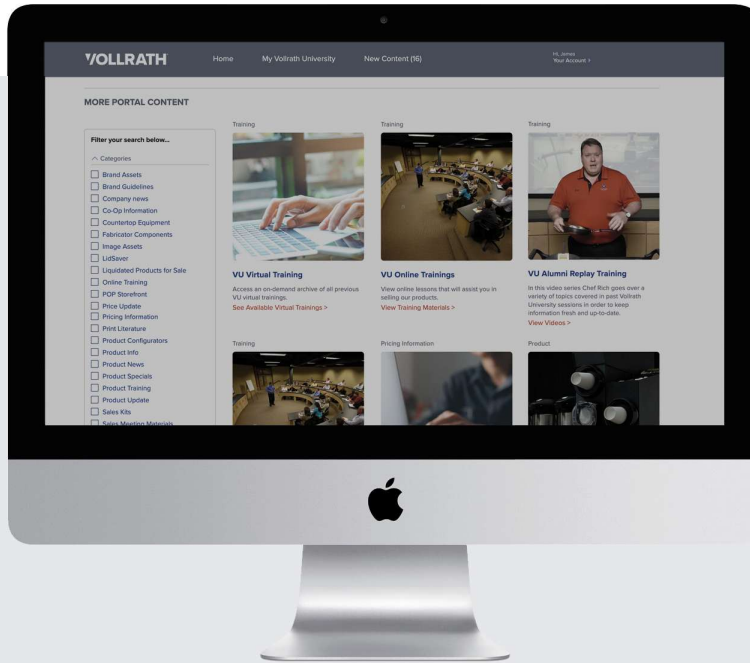

Vollrath Foodservice Portal

You can view all of our previous webinars and trainings on demand inside of the Vollrath Foodservice Portal.

These online resources will help you gain insights into the wide world of foodservice and will provide information on how our key products can benefit you or your customers.

If you do not have a VFS Portal account or need assistance in accessing your account, please use the appropriate QR code below.



SCAN HERE FOR INSTRUCTIONS ON HOW TO CREATE YOUR PORTAL ACCOUNT



SCAN HERE TO VIEW A VIDEO ON HOW TO USE THE VOLLRATH PORTAL

New Products



Stay up to date with our latest innovative, industry-leading products that bring creative proficiency to today's foodservice operations.



Project Gallery

At Vollrath, we are dedicated to producing top-of-the-line carts, kiosks, and inline systems that are built to perform. Learn about our extensive array of capabilities, view samples of our work in our project galleries, and read about our philosophy to see how we earned our reputation for offering the industry's most strategically branded carts and kiosks.



Inspiration Blog

Spark your imagination, fuel your creative spirit, and carry the foodservice industry forward with case studies, articles and more.



DISCOVER MORE

Custom Products



At Vollrath, we understand that in the fast-paced world of food, adaptability and precision are key. That's why we're proud to offer custom products that cater to the unique needs of your restaurant. When you have a problem with seemingly no resolution, our custom solutions ensure you can bring your culinary visions to life with ease. These products are designed to streamline your kitchen operations, fitting seamlessly into your workflow, optimizing every product for maximum efficiency. With Vollrath's custom products, you can maintain strict portion control, ensuring that every dish leaving your kitchen is of the highest quality and presentation.

CUSTOM PRODUCTS PROJECTS



Smallwares

Meatloaf Lifter

Benefit: Improved Efficiency



Countertop Equipment

Half-Size Long Warmer

Benefit: Smaller Footprint & Portability



Serving Systems

Branded Kiosk

Benefit: Increased Sales in Alternative Location



Staeling® Frozen Treat Equipment

Yogurt Machine

Benefit: Less-Touch Dispenser

CUSTOM PRODUCTS PROCESS

- 1 CONSULTATION WITH VOLLRATH SALES REPRESENTATIVE
- 2 FORM SUBMISSION
- 3 CONSULTATION WITH VOLLRATH ENGINEERING TEAM
- 4 CONCEPT/DRAWING
- 5 PROTOTYPE
- 6 TEST (IN LAB OR IN FIELD)
- 7 PRODUCTION
- 8 INVENTORY/SHIP
- 9 POST-SALES SUPPORT

DISCOVER MORE

Vollrath Smallwares



These are the small wonders that turn mere ingredients into culinary innovation. Set yourself up for success from prep to cook and beyond with our best-in-class commercial kitchen smallwares collection.



Vollrath Countertop Equipment



Our countertop equipment and restaurant appliances are designed to be the set of reliable, dependable helping hands you need when you're at your busiest, including conveyor toasters and ovens, countertop griddles and the best induction cooktops on the market.





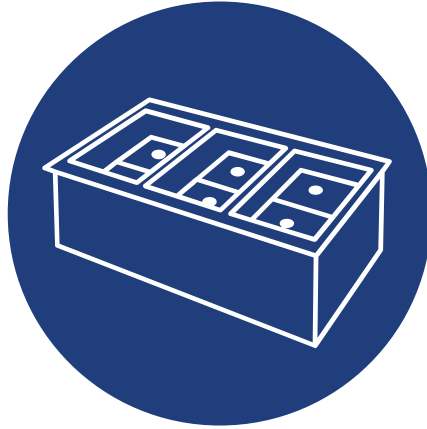

Fabricator Components

We know creating a custom design involves a lot of decisions – and it can be time-consuming to get approval from your whole team. We'll help you through every step of the process. On the pages that follow, you'll find a selection of components that can be used to build your ideal serving system. Take a look, and then give us a call. We're ready to make something functional and beautiful.



**Induction
Drop-Ins**



**Hot
Drop-Ins**



**Cold
Drop-Ins**



**Combination
Hot & Cold
Drop-Ins**



**FlexVent™
Versatile Slide-In**



**Drop-In
Display Cases**



Sinks



Breath Guards



**Heated Shelves
and Heat Strips**

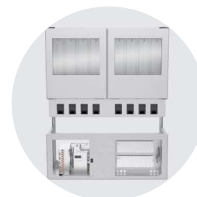

**SerVue™
Touchless Slide-In**

How To Shop

Induction Drop-Ins

Induction drop-ins heat food quickly and keep it hot without water. There's no filling, no refilling, and no scaling. They start up immediately and allow you to set a precise temperature or choose a power level. No water, no steam, no drain, no hassle.

PAGES 10-17



MODULAR INDUCTION DRY WELL DROP-INS
PAGES 10-15



ROUND INDUCTION DRY WELL DROP-INS
PAGES 16-17

Hot Drop-Ins

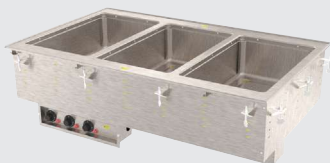

Available in a wide range of container sizes and shapes, our hot drop-ins maintain the freshness and quality of the food.

PAGES 10-24



FABRICATOR WELLS
PAGES 10-11, 18



DROP-IN WARMERS
PAGES 10-11, 20



MODULAR HOT DROP-INS
PAGES 10-11, 19, 21, 22-24

Cold Drop-Ins



Available in a wide range of container sizes and shapes, our cold drop-ins maintain the freshness and quality of the food.

PAGES 25-28



NONREFRIGERATED DROP-INS
PAGES 25-26



REFRIGERATED DROP-INS
PAGES 26-27



NSF REFRIGERATED DROP-INS
PAGES 27-28



REFRIGERATED FROST TOPS
PAGE 28

Combination Hot/Cold Drop-Ins

Can change from a cold salad bar to a hot buffet – or a combination – with the flip of a switch.

PAGE 29



Induction Ranges

With impressive induction technology, Vollrath drop-in ranges are a valuable addition to any lineup and approximately 40 percent more efficient than electric or gas.

PAGES 30-31



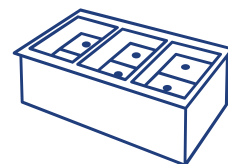

NEW//

FlexVent™ Versatile Slide-In



Safe, sleek and self-contained, a FlexVent™ versatile slide-in makes presentation cooking more captivating than ever, so it's sure to be the star of your serving line.

PAGES 32-33

Light and Heat Strips, Heated Shelves



Our line of durable light and heat strips and reliable heated shelves allows you to keep all your best food items on display, within reach and appetizingly fresh.

PAGES 46-50

Sinks

Constructed of 20- or 22-gauge stainless steel, our sinks are built to withstand the tough demands of your kitchen.



PAGES 34-37

Display Cases



Small or large, heated or refrigerated, our dependable drop-in display cases easily and consistently exceed expectations. The sleek design, powerful temperature controls and interior lighting keep your food items in perfect condition.

PAGE 51

Dispensers & Organizers



Maximize limited space and keep operations tidy at busy self-serve stations with the LidSaver®3 dispenser and a full line of straw, condiment, tissue, napkin, and a variety of other dispensers.

PAGES 38-41

NEW//

SerVue™ Touchless Slide-In



The freshest idea in food bars is here. The SerVue™ family of touchless slide-in units combines artful presentation with easy, interactive dispensing.

PAGES 52-53

Breath Guards

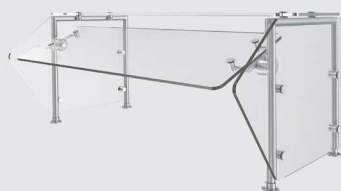

Don't leave your delicious creations defenseless. Our line of breath guards features the perfect combination of protection and visibility in a wide variety of sizes and styles.

PAGES 42-45



Drop-Ins Overview

The Industry's Most Complete Line Of Hot Drop-In Technology

With six specially designed hot well solutions, Vollrath features the most extensive range of hot well technology in the industry. So no matter what your serving application calls for, Vollrath can fit your needs with the configuration and fabricator components to keep your food fresh and flavorful.

- Extensive range of configurations – from single well to six wells
- Available in both standard and short side layout
- Professionally display and serve hot and cold food
- Single cord and plug for simple installation
- Intuitive controls for effortless operation
- Diverse collection of fabricator components



	PRICE LEVEL	WATER REQUIRED	DRAIN REQUIRED	OPERATION SAFETY	ENERGY EFFICIENCY	EASE OF USE	PRECISION OF TEMPERATURE
FABRICATOR WELLS							
	\$	✓	✓	★★★★	★★★★	★★★★	★★
THERMOSET DROP-IN WARMERS							
	\$	✓	✓	★★★★	★★★★	★★★★	★★
MODULAR STEAM HOT WELLS							
	\$\$	✓	✓	★★★★	★★★★	★★★★	★★
MODULAR STEAM WELLS WITH MARINE-GRADE WELLS							
	\$\$\$	✓	✓	★★★★	★★★★	★★★★	★★
MODULAR DRY HOT WELLS							
	\$\$	-	-	★★★★	★★★★	★★★★	★★
MODULAR INDUCTION DRY HOT WELLS							
	\$\$\$\$	-	-	★★★★★	★★★★★	★★★★★	★★★★★



HEAT ZONE
FLEXIBILITY

PAN CONFIGURATION
FLEXIBILITY

EASE OF
INSTALLATION

ELEMENT
CONCEALMENT

CORROSION
RESISTANCE

WARRANTY

OF WELL
OPTIONS

★★★★

★★★★★

★★★★★

★★★★★

★★★★

1 YEAR

1 WELL

★★★★

★★★★★

★★★★★

★★★★★

★★★★★

1 YEAR

1 WELL

★★★★

★★★★★

★★★★★

★★★★★

★★★★

1 YEAR

6 (1-6 WELLS)

★★★★

★★★★★

★★★★★

★★★★★

★★★★★

2 YEAR

6 (1-6 WELLS)

★★★★

★★★★★

★★★★★

★★

★★★★

1 YEAR

6 (1-6 WELLS)

★★★★★

★★★★

★★★★★

★★★★★

★★★★

1 YEAR

6 (1-6 WELLS)



Modular Induction Dry Well Drop-Ins

Look inside the modular induction dry well drop-in system from Vollrath and discover a smarter way to serve. Inspired by our proven induction soup well and range performance, the Vollrath dry well drop-in system uses induction technology to deliver optimal hot food holding and precise temperature control in a waterless well. Offering unmatched flexibility, the dry well system features the option of as little as one or as many as six wells. See how smarter thinking results in better serving.



ROBUST THERMISTOR

Provides intelligent control and a durable, easy-to-clean design.

ALTERNATING MAGNETIC FIELD

Induction technology creates a safer, more controlled warming system.

RETRACTABLE NYLON RISERS

Easily adjustable risers accommodate 2.5" and 4" pan depths.

ACCESS & SERVICEABILITY

Power electronics located outside of well for easier maintenance.

DUAL INDUCTION

Two independent heating zones per well provide flexibility.



INTELLIGENT ZONE COMMUNICATION

Synchronized coil frequencies create minimal operating noise.

ELECTROMAGNETIC INDUCTION

Completely dry system eliminates the use of water and steam.

SUPER PAN V® INDUCTION-READY PANS

Induction-ready pans are designed to optimize compatibility and warming performance.

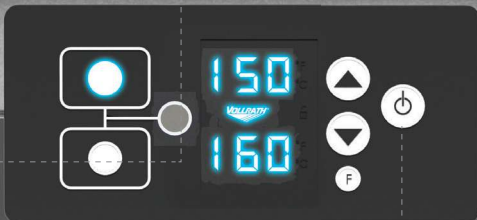

TEMPERATURE/POWER CONTROL

Adjustable control allows precise temperature setting or choice of three power levels in order to maintain the freshness and quality of the food.

STAINLESS STEEL WELL & FLANGE

Durable, commercial-grade material is easy to clean and matches existing equipment.



Features & Benefits

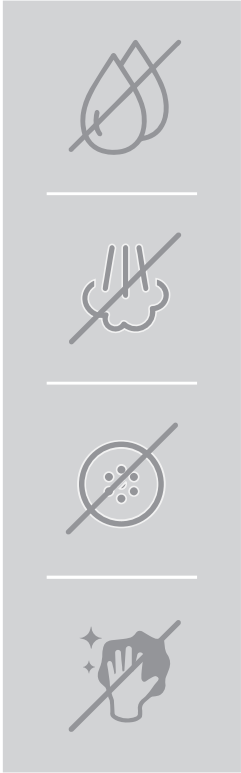

PRECISE TEMPERATURE CONTROL

Two induction zones per well with adjustable temperature control.



SAFER OPERATION

No hot steam, hot water, or hot flanges.



INCREASED EFFICIENCY

2.9 times more energy efficient than steam warming systems.



INDIVIDUAL SYNCED CONTROLS

More precision and control to maintain freshness and quality.

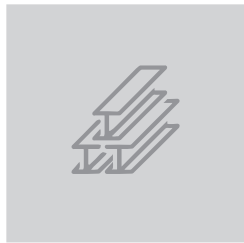

STAINLESS STEEL WELL & FLANGE

Durable, commercial-grade material is easy to clean and matches existing equipment.

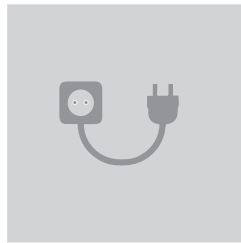

CORD & PLUG INSTALLATION

Effortless installation with no hard-wiring required.

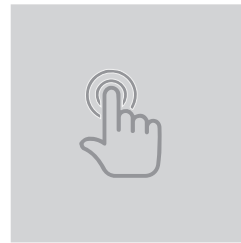

ACCESS & SERVICEABILITY

Power electronics located outside of well for easier maintenance.



FLEXIBLE INSTALLATION

Installation in all countertop types up to 3" thick and available in 1-6 wells.

INDUCTION TECHNOLOGY

Eliminates water, steam, drains, and hassle.

PAIRED PERFORMANCE

Super Pan V® induction-ready pans are the only pans designed for use with the Vollrath induction dry well drop-ins. Together they provide optimized compatibility and warming performance.





Modular Induction Dry Well Drop-Ins

ITEM #	DESCRIPTION	OVERALL DIMENSIONS (W X D): IN (CM)	VOLTAGE: AC	AMPS	TOTAL WATTS	HZ	PLUG	CASE LOT
FC-6IH-01120	1-well induction dry well drop-in	15 x 26 (38.1 x 66)	120	6.6	800	60	NEMA 5-15P	1
FC-6IH-01208	1-well induction dry well drop-in	15 x 26 (38.1 x 66)	208-240	3.3	800	60	NEMA 6-15P	1
FC-6IH-02120	2-well induction dry well drop-in	28 x 26 (71.8 x 66)	120	13.2	1,590	60	NEMA 5-20P	1
FC-6IH-02208	2-well induction dry well drop-in	28 x 26 (71.8 x 66)	208-240	6.6	1,590	60	NEMA 6-15P	1
FC-6IH-03120	3-well induction dry well drop-in	41 x 26 (105.4 x 66)	120	19.8	2,380	60	NEMA 5-30P	1
FC-6IH-03208	3-well induction dry well drop-in	41 x 26 (105.4 x 66)	208-240	9.9	2,380	60	NEMA 6-15P	1
FC-6IH-04208	4-well induction dry well drop-in	54 x 26 (139 x 66)	208-240	13.2	3,180	60	NEMA 6-20P	1
FC-6IH-05208	5-well induction dry well drop-in	68 x 26 (172.7 x 66)	208-240	16.5	3,980	60	NEMA 6-30P	1
FC-6IH-06208	6-well induction dry well drop-in	81 x 26 (206.4 x 66)	208-240	19.8	4,760	60	NEMA 6-30P	1



Super Pan V[®] Induction-Ready Pans

- The only pan paired to work with Vollrath induction dry well drop-ins
- Constructed of 22-gauge, induction-optimized stainless steel
- Pour corners designed to resist dents and dings in the toughest kitchen environments
- Smooth curves and natural finish for a show-stopping look
- Easy to clean functionality means Super Pan V[®] pans will present your food beautifully over a long time
- NSF listed



ITEM #	DESCRIPTION	CAPACITY: QT (L)	DIMENSIONS (D X W): IN (MM)	SOLID COVER	SLOTTED COVER	FALSE BOTTOM	CASE LOT
51PF25	Full-size 2½" (6.4 cm) deep	9.3 (8.8)	20¾ x 12¾ (527 x 324)	77250	75210*	20000	6
51PF40	Full-size 4" (10.2 cm) deep	14 (13.3)	20¾ x 12¾ (527 x 324)	77250	75210*	20000	6
51PH25	Half-size 2½" (6.4 cm) deep	4.3 (4.1)	10¾ x 12¾ (264 x 324)	75120	75220*	20000	6
51PH40	Half-size 4" (10.2 cm) deep	6.7 (6.3)	10¾ x 12¾ (264 x 324)	75120	75220*	20000	6

*Slotted covers are not NSF





Round Induction Dry Well Drop-Ins

ELIMINATE WATER, NO FILLING AND REFILLING, NO SCALING, NO WATER ON COUNTERS, NO MANIFOLDS OR DRAINS

3D induction coils act like steam, but without the water

INCREASE FOOD YIELD, MINIMIZE FOOD WASTE

Three-thermistor temperature sensing on the food inset stops soups and foods from burning

REDUCE ENERGY COSTS WITH LOW AMP DRAW

250W warmers are 120V and 2.1 amps;
800W rethermalizers are 120V and 6.7 amps

EASY AND SECURE TEMPERATURE CONTROL

Precise 1° temperature settings on induction soup rethermalizers

FAST RETHERMALIZING TIMES

Fast, efficient induction takes 50-60 minutes to rethermalize foods versus 1½ hours in most other units

MAINTAIN CONTROL OVER TEMPERATURE SETTINGS

Unique hold feature locks the temperature in place

KEEP SOUPS PROPERLY STIRRED

Stir indicator measures temperature differences and reminds operators to stir

EASY TO USE

Bright LED display with easy-to-use controls

IMMEDIATE STARTUP, NO PREHEATING

Induction heats the inset directly without a steam bath, which requires a preheat



**International models only*





Round Induction Drop-Ins

- Includes mounting hardware
- No manifolds or drains
- Ships with induction-ready inset and standard hinged cover

Round induction rethermalizers also available as countertop models



ITEM #	DESCRIPTION	DIMENSIONS (W X H): IN (CM)	DROP-IN MAX WIDTH: IN (CM)	WELL DEPTH: IN (CM)	VOLTAGE: AC	WATTS	AMPS	PLUG
74701DW	7 qt induction warmer	11 ⁷ / ₈ x 12 ⁵ / ₁₆ (30.3 x 31.3)	10 ⁷ / ₁₆ (26.5)	6 ⁷ / ₈ (17.6)	120	250	2.1	5-15P
74701D	7 qt induction rethermalizer	11 ⁷ / ₈ x 13 ¹ / ₂ (30.3 x 34.2)	10 ⁷ / ₁₆ (26.5)	6 ⁷ / ₈ (17.6)	120	800	6.7	5-15P
741101DW	11 qt induction warmer	13 ⁷ / ₈ x 13 ¹ / ₂ (35.3 x 34.2)	12 ⁷ / ₁₆ (31.2)	6 ⁷ / ₈ (17.6)	120	250	2.1	5-15P
741101D	11 qt induction rethermalizer	13 ⁷ / ₈ x 13 ¹ / ₂ (35.3 x 34.2)	12 ⁷ / ₁₆ (31.2)	6 ⁷ / ₈ (17.6)	120	800	6.7	5-15P



For 7 qt international models with 220-240V, change the fifth digit to "2" for Schuko, "3" for UK, "4" for China or "5" for Australia (i.e., Schuko 7470110 to 7470210)
 For 11 qt international models with 220-240V, change the sixth digit to "2" for Schuko, "3" for UK, "4" for China or "5" for Australia (i.e., Schuko 74110110 to 74110210)



Round Induction Drop-In Accessories

CONTEMPORARY HINGED INSET LIDS

- Welded handle is permanently attached and stays secured to cover
- No-friction tabs to lose
- Handle serves as kickstand, keeping cover open for easy access to food
- Design of handle dissipates heat, keeping it cooler to the touch
- Large opening for easy access
- Fits most 7-quart or 11-quart insets

HINGED COVER

- Welded clips on stationary side of cover hold it securely in place
- Kool-Touch® phenolic knob handle
- Slot for ladles or spoons when cover is closed
- Easy one-hand operation

STAINLESS STEEL DECORATIVE RINGS

- Easy to install
- Durable 22-gauge stainless steel
- Provides an upscale, aesthetically pleasing look



ITEM #	DESCRIPTION	STANDARD COVER ITEM #	CONTEMPORARY HINGED LID #
88184	7 ¹ / ₄ qt. induction inset	47488	47493
88204	11 qt. induction inset	47400	47494
88184NS	7 ¹ / ₄ qt. induction inset	47488	47493
88204NS	11 qt. induction inset	47400	47494
47491	7 ¹ / ₄ qt. stainless steel ring	—	—
47492	11 qt. stainless steel ring	—	—





Hot Drop-Ins

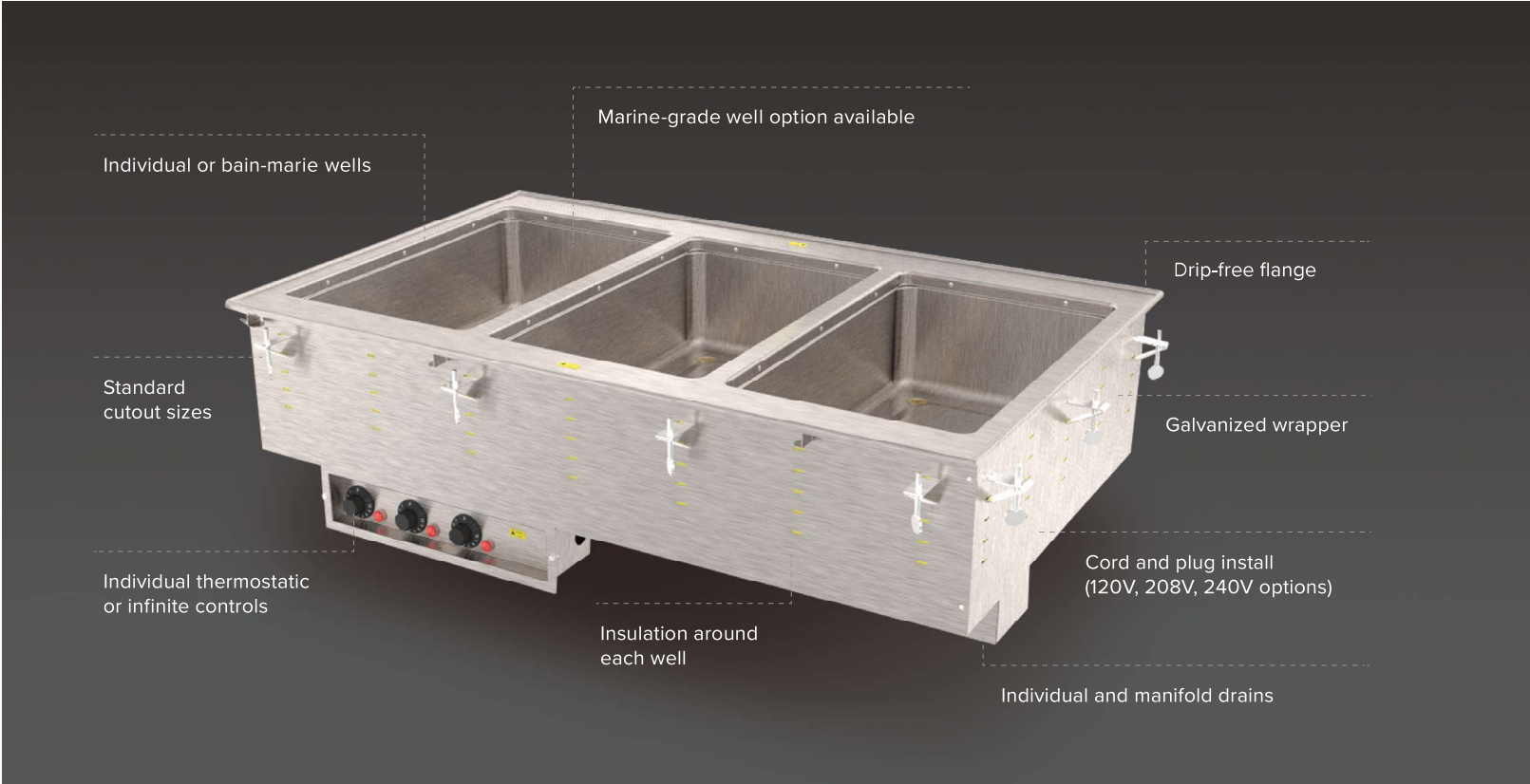

Top-Mount Fabricator Well

- Designed for top-mount installation and requires hard-wiring
- High-density glass fiber insulation allows use of 1,000W elements
- Zero clearance for flexibility in installation
- Available for 120V, 208-240V power
- Beveled edge for easy cleaning
- Thermostatic control
- 4-foot flexible control cable
- Hard-wired input power connections
- Recommend using up to 4" (10.2 cm) deep pans – full and fractional sizes



ITEM #	OVERALL DIMENSIONS (W X D): IN (CM)	WATTS	VOLTAGE: AC	AMPS
36368	15 x 23 (38.1 x 58.4)	1000	120	8.3
36369	15 x 23 (38.1 x 58.4)	750-1000	208-240	3.6-4.2

With 3/8" (2.2 cm) corner radius Note: Modular drop-ins cannot be canceled or returned





Modular Dry Hot Drop-Ins

- Zero clearance installation – no trim rings required for installation in nonmetallic countertops
- Waterless – no need to manage water and drainage
- Accommodate pans up to 6" in depth
- Choice of infinite or thermostatic controls
- Cord and plug installation
- Open-element design
- Standard one-year warranty



ITEM #	DESCRIPTION	CONTROL TYPE	VOLTAGE: AC
FC-4DH-01120-I	1-well hot dry drop-in	Infinite	120
FC-4DH-01208-I	1-well hot dry drop-in	Infinite	208-240
FC-4DH-01120-T	1-well hot dry drop-in	Thermostatic	120
FC-4DH-01208-T	1-well hot dry drop-in	Thermostatic	208-240
FC-4DH-02120-I	2-well hot dry drop-in	Infinite	120
FC-4DH-02208-I	2-well hot dry drop-in	Infinite	208-240
FC-4DH-02120-T	2-well hot dry drop-in	Thermostatic	120
FC-4DH-02208-T	2-well hot dry drop-in	Thermostatic	208-240
FC-4DH-03120-I	3-well hot dry drop-in	Infinite	120
FC-4DH-03120-I	3-well hot dry drop-in	Infinite	208-240
FC-4DH-03120-T	3-well hot dry drop-in	Thermostatic	120
FC-4DH-03208-T	3-well hot dry drop-in	Thermostatic	208-240
FC-4DH-04208-I	4-well hot dry drop-in	Infinite	208-240
FC-4DH-04208-T	4-well hot dry drop-in	Thermostatic	208-240
FC-4DH-05208-I	5-well hot dry drop-in	Infinite	208-240
FC-4DH-05208-T	5-well hot dry drop-in	Thermostatic	208-240
FC-4DH-06208-I	6-well hot dry drop-in	Infinite	208-240
FC-4DH-06208-T	6-well hot dry drop-in	Thermostatic	208-240

*Items are made to order and cannot be canceled or returned



Bottom-Mount Fabricator Well

- Designed for bottom-mount installation and requires hard-wiring
- Beveled edge for easy cleaning
- Thermostatic control
- Deep drawn well is 20-gauge 18-8 stainless steel
- Meets NSF performance standards
- Allows use of full-size and fractional pans up to 6" (15.2 cm) deep while still providing moist heat



ITEM #	WELL*	OVERALL DIMENSIONS (W X D): IN (CM)	REMOTE CONTROL LEADS: IN (CM)	WATTS	VOLTAGE: AC	AMPS
36352	I	14 ³ / ₃₂ x 22 ¹ / ₈ (35.8 x 56.2)	36 (91.4)	1000	120	8.3
36353	I	14 ³ / ₃₂ x 22 ¹ / ₈ (35.8 x 56.2)	72 (182.9)	1000	120	8.3
36354	I	14 ³ / ₃₂ x 22 ¹ / ₈ (35.8 x 56.2)	36 (91.4)	1000	208-240	3.6-4.2
36355	I	14 ³ / ₃₂ x 22 ¹ / ₈ (35.8 x 56.2)	72 (182.9)	1000	208-240	3.6-4.2
36356	V	14 ³ / ₃₂ x 22 ¹ / ₈ (35.8 x 56.2)	36 (91.4)	1000	120	8.3
36360	V	14 ³ / ₃₂ x 22 ¹ / ₈ (35.8 x 56.2)	72 (182.9)	1000	120	8.3
36358	V	14 ³ / ₃₂ x 22 ¹ / ₈ (35.8 x 56.2)	36 (91.4)	1000	208-240	3.6-4.2
36359	V	14 ³ / ₃₂ x 22 ¹ / ₈ (35.8 x 56.2)	72 (182.9)	1000	208-240	3.6-4.2

*I = Industry and V = Vollrath wells Note: Modular drop-ins cannot be canceled or returned





Cayenne® Drop-In Warmers

- Thermoset fiber-reinforced resin well – self-insulating for maximum energy efficiency
- 6-foot cord and plug or hard-wired
- Top mounts
- Low-water indicator light eliminates guesswork
- Drain models allow for easy cleaning
- Recommend using up to 4" (10.2 cm) deep pans – full and fractional sizes



ITEM #	DESCRIPTION	DIMENSIONS (L X W X H): IN (CM)	VOLTAGE: AC	WATTS	AMPS	PLUG
US MODELS**						
72105	Model 3001D drop-in warmer with drain, unit-mounted control	21¾ x 13¾ x 9 (55 x 33 x 23)	120	700	5.8	5-15P
72107	Model 3002D drop-in warmer with drain, front-mounted control panel with flexible conduit control panel cutout dimensions: 5" x 3½" (12.7 x 8.9 cm), no low-water indicator light	21¾ x 13¾ x 9 (55 x 33 x 23)	120	700	5.8	Hard Wire
72109*	Model TD43R-DI 4/3 thermoset drop-in warmer with integral drain, front-mounted control panel with flexible conduit control panel dimensions: 5⅝" x 5½" (14.3 x 14 cm)	28¾ x 13¾ x 13⅞ (73 x 34.9 x 33.2)	120	1600	13.3	5-15P
72112****	Model TD43R-DI 4/3 thermoset drop-in warmer with integral drain, front-mounted control panel with flexible conduit control panel dimensions: 5⅝" x 5½" (14.3 x 14 cm)	28¾ x 13¾ x 13⅞ (73 x 34.9 x 33.2)	240	1600	7.7	6-15P
CANADA MODELS — AVAILABLE FOR CANADA ONLY**						
72111	Model TD43R-DI 4/3 thermoset drop-in warmer with integral drain, front-mounted control panel with flexible conduit control panel dimensions: 5⅝" x 5½" (14.3 x 14 cm)	28¾ x 13¾ x 13⅞ (73 x 34.9 x 33.2)	120	1600	13.3	5-20P
INTERNATIONAL MODELS — AVAILABLE FOR EXPORT ONLY***						
72610	Model 3001 drop-in warmer	21¾ x 13¾ x 9 (55 x 33 x 23)	230	700	3.0	Schuko
72560	Model 3001D drop-in warmer with drain	21¾ x 13¾ x 9 (55 x 33 x 23)	230	700	3.0	UK

*5-foot cord and plug **cULus certified ***CE certified ****U.S. and Canadian model Note: Modular drop-ins cannot be canceled or returned



*International models only

Cayenne® Model 2001 Drop-In Warmer

- Stainless steel 6½" (16.6 cm) deep well
- Durable stainless steel exterior for longer life
- Instant drop-in without permanent wiring, plumbing, or installation costs
- Positioning pins hold unit in place
- 6-foot cord and plug – no wiring required
- Meets NSF 4 performance standards
- Recommend using up to 4" (10.2 cm) deep pans – full and fractional sizes



ITEM #	DIMENSIONS (L X W X H): IN (CM)	VOLTAGE: AC	WATTS	AMPS	PLUG
72001	24 x 15 x 8⅝ (61 x 38.1 x 21.9)	120	1000	8.3	5-15P

Note: Modular drop-ins cannot be canceled or returned





Round Modular Hot Drop-Ins

- 6-foot (183 cm) power cord and 4-foot (122 cm) control cord
- Double-wall construction
- Deep-drawn stainless wells
- High-density glass fiber insulation
- ¾" (1.9 cm) drain with ball valve shut-off
- Well height: 7 1/16" (19.5 cm)



Mounting brackets standard



INFINITE CONTROL ITEM #	THERMOSTATIC CONTROL ITEM #	HOLDS INSET SIZE: QT (L)	DIAMETER OVER FLANGE: IN (CM)	WELL OUTER DIAMETER: IN (CM)	WATTS	VOLTAGE: AC	AMPS	PLUG
36462	3646210	7¼ (6.9)	11 3/16 (28.4)	10 5/16 (26.2)	720	120	6	5-15P
36464	3646410	11 (10.5)	12 13/16 (32.5)	12 (30.5)	720	120	6	5-15P
36463	3646310	7¼ (6.9)	11 13/16 (28.4)	10 5/16 (26.2)	720-960	208-240	3.5-4	6-15P
36465	3646510	11 (10.5)	12 13/16 (32.5)	12 (30.5)	720-960	208-240	3.5-4	6-15P

Note: Modular drop-ins cannot be canceled or returned



Bain-Marie Hot Drop-Ins

- Open design allows for use of templates
- Thermostat controls temperature accurately and maintains steam for safe food warming
- Well depth: 6 5/8" (16.8 cm)



DESCRIPTION	WATTS	120V ITEM #	AMPS	PLUG	208V ITEM #	AMPS	PLUG	240V ITEM #	AMPS	PLUG	OVERALL DIMENSIONS (W X D): IN (CM)	INTERIOR LENGTH: IN (CM)
2-pan	1250	36500	10.4	5-15P	36501208	6	6-15P	36501240	5.2	6-15P	29 x 26 (73.7 x 66)	24 3/4 (62.9)
3-pan	1875	36502	15.6	5-20P	36503208	9	6-15P	36503240	7.8	6-15P	41 1/2 x 26 (105.4 x 66)	37 1/2 (95.3)
4-pan	2500	—	—	—	36504208	12	6-20P	36504240	10.4	6-15P	54 3/4 x 26 (139.1 x 66)	50 1/4 (127.6)
5-pan	3125	—	—	—	36505208	15	6-20P	36505240	13	6-20P	68 x 26 (172.7 x 66)	63 (160)
6-pan	3750	—	—	—	36506208	18	6-30P	36506240	15.6	6-20P	81 1/4 x 26 (206.4 x 66)	75 3/4 (192.4)

With 7/8" (2.2 cm) corner radius. Designed for warming food pans only – not for use as a rethermalizing water vessel

Note: Modular drop-ins cannot be canceled or returned





Hot Drop-Ins With Marine-Grade Wells

- Marine-grade stainless steel stands up to hard water and harsh cleaning techniques and offers enhanced corrosion resistance
- High-density glass fiber insulation on the sides, ends, and below the element traps heat and maximizes energy efficiency
- Reliable thermostatic controls ensure accurate heating
- Detachable control unit for remote mounting
- Energy-efficient heating element uses smaller circuit and reduces installation costs while offering comparable performance to higher-wattage elements

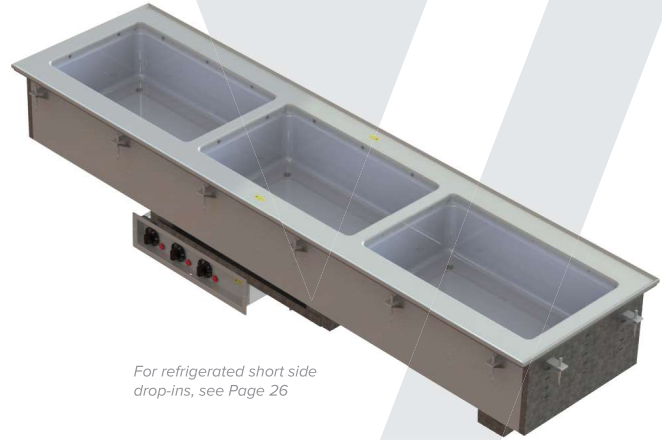

For refrigerated short side drop-ins, see Page 26

Short Side Hot Drop-Ins

- Short side drop-ins turn full-size pans sideways for a more narrow presentation and easy reach
- Ideal for when you pull food forward or are tight on counter space depth
- Add “HD” to item number for marine-grade well

1000W STANDARD DRAIN	MANIFOLD DRAIN	MANIFOLD WITH AUTOFILL	VOLTAGE: AC	AMPS	PLUG	CONTROL
2-WELL						
36646	3664620	3664630	208-240	7.2-8.3	6-15P	Thermostatic
36647	3664720	3664730	208-240	7.2-8.3	6-15P	Infinite
3-WELL						
36648	3664820	3664830	208-240	10.8-12.5	6-20P	Thermostatic
36649	3664920	3664930	208-240	10.8-12.5	6-20P	Infinite
4-WELL						
36650	3665020	3665030	208-240	14.4-16.7	6-30P	Thermostatic
36651	3665120	3665130	208-240	14.4-16.7	6-30P	Infinite
625W STANDARD DRAIN	MANIFOLD DRAIN	MANIFOLD WITH AUTOFILL	VOLTAGE: AC	AMPS	PLUG	CONTROL
2-WELL						
36640	3664020	3664030	120	10.4	5-15P	Thermostatic
36641	3664120	3664130	120	10.4	5-15P	Infinite
3-WELL						
36642	3664220	3664230	120	15.6	5-20P	Thermostatic
36643	3664320	3664330	120	15.6	5-20P	Infinite
4-WELL						
36644	3664420	3664430	120	20.8	5-30P	Thermostatic
36645	3664520	3664530	120	20.8	5-30P	Infinite

With 7/8" (2.2 cm) corner radius Note: Modular drop-ins cannot be canceled or returned
 Note: HD wells have two-year warranty





1-Well Hot Drop-Ins

- Overall dimensions: 15" x 26" (38 x 66 cm)
- Add "HD" to item number for marine-grade well



1000W STANDARD DRAIN	MANIFOLD WITH AUTOFILL	VOLTAGE: AC	AMPS	PLUG	CONTROL
3646601	3646661	120	8.3	5-15P	Infinite
3646611	3646681	120	8.3	5-15P	Thermostatic
3646701	3646761	208-240	3.6-4.2	6-15P	Infinite
3646711	3646781	208-240	3.6-4.2	6-15P	Thermostatic

625W STANDARD DRAIN	MANIFOLD WITH AUTOFILL	VOLTAGE: AC	AMPS	PLUG	CONTROL
36466	3646660	120	5.2	5-15P	Infinite
3646610	3646680	120	5.2	5-15P	Thermostatic
36467	3646760	208	3.0	6-15P	Infinite
3646710	3646780	208	3.0	6-15P	Thermostatic
36471	3647160	240	2.6	6-15P	Infinite
3647110	3647180	240	2.6	6-15P	Thermostatic

Note: Modular drop-ins cannot be canceled or returned
 Note: HD wells have two-year warranty



2-Well Hot Drop-Ins

- Overall dimensions: 28¼" x 26" (71.8 x 66 cm)
- Add "HD" to item number for marine-grade well



1000W STANDARD DRAIN	MANIFOLD DRAIN	MANIFOLD WITH AUTOFILL	VOLTAGE: AC	AMPS	PLUG	CONTROL
3639901	3639951	3639961	120	16.7	5-30P	Infinite
3639911	3639971	3639981	120	16.7	5-30P	Thermostatic
3640001	3640051	3640061	208-240	7.2-8.3	6-15P	Infinite
3640011	3640071	3640081	208-240	7.2-8.3	6-15P	Thermostatic

625W STANDARD DRAIN	MANIFOLD DRAIN	MANIFOLD WITH AUTOFILL	VOLTAGE: AC	AMPS	PLUG	CONTROL
36399	3639950	3639960	120	10.4	5-15P	Infinite
3639910	3639970	3639980	120	10.4	5-15P	Thermostatic
36400	3640050	3640060	208	6.0	6-15P	Infinite
3640010	3640070	3640080	208	6.0	6-15P	Thermostatic
36472	3647250	3647260	240	5.2	6-15P	Infinite
3647210	3647270	3647280	240	5.2	6-15P	Thermostatic

Note: Modular drop-ins cannot be canceled or returned
 Note: HD wells have two-year warranty



3-Well Hot Drop-Ins

- Overall dimensions: 41½" x 26" (105.4 x 66 cm)
- Add "HD" to item number for marine-grade well



1000W STANDARD DRAIN	MANIFOLD DRAIN	MANIFOLD WITH AUTOFILL	VOLTAGE: AC	AMPS	PLUG	CONTROL
3640401	3640451	3640461	120	25	5-50P	Infinite
3640411	3640471	3640481	120	25	5-50P	Thermostatic
3640501	3640551	3640561	208-240	10.8-12.5	6-20P	Infinite
3640511	3640571	3640581	208-240	10.8-12.5	6-20P	Thermostatic

625W STANDARD DRAIN	MANIFOLD DRAIN	MANIFOLD WITH AUTOFILL	VOLTAGE: AC	AMPS	PLUG	CONTROL
36404	3640450	3640460	120	15.6	5-20P	Infinite
3640410	3640470	3640480	120	15.6	5-20P	Thermostatic
36405	3640550	3640560	208	9.0	6-15P	Infinite
3640510	3640570	3640580	208	9.0	6-15P	Thermostatic
36473	3647350	3647360	240	7.8	6-15P	Infinite
3647310	3647370	3647380	240	7.8	6-15P	Thermostatic

Note: HD wells have two-year warranty
 Note: Modular drop-ins cannot be canceled or returned





4-Well Hot Drop-Ins

- Overall dimensions: 54¾" x 26" (139.1 x 66 cm)
- Add "HD" to item number for marine-grade well



1000W STANDARD DRAIN	MANIFOLD DRAIN	MANIFOLD WITH AUTOFILL	VOLTAGE: AC	AMPS	PLUG	CONTROL
3640701	3640751	3640761	208-240	14.4-16.7	6-30P	Infinite
3640711	3640771	3640781	208-240	14.4-16.7	6-30P	Thermostatic

625W STANDARD DRAIN	MANIFOLD DRAIN	MANIFOLD WITH AUTOFILL	VOLTAGE: AC	AMPS	PLUG	CONTROL
36406	3640650	3640660	120	20.8	5-30P	Infinite
3640610	3640670	3640680	120	20.8	5-30P	Thermostatic
36407	3640750	3640760	208	12.0	6-15P	Infinite
3640710	3640770	3640780	208	12.0	6-15P	Thermostatic
36474	3647450	3647460	240	10.4	6-15P	Infinite
3647410	3647470	3647480	240	10.4	6-15P	Thermostatic

Note: HD wells have two-year warranty
 Note: Modular drop-ins cannot be canceled or returned



5-Well Hot Drop-Ins

- Overall dimensions: 68" x 26" (172.7 x 66 cm)
- Add "HD" to item number for marine-grade well



1000W STANDARD DRAIN	MANIFOLD DRAIN	MANIFOLD WITH AUTOFILL	VOLTAGE: AC	AMPS	PLUG	CONTROL
3640801	3640851	3640861	208-240	18-20.8	6-30P	Infinite
3640811	3640871	3640881	208-240	18-20.8	6-30P	Thermostatic

625W STANDARD DRAIN	MANIFOLD DRAIN	MANIFOLD WITH AUTOFILL	VOLTAGE: AC	AMPS	PLUG	CONTROL
36408	3640850	3640860	208	15.0	6-20P	Infinite
3640810	3640870	3640880	208	15.0	6-20P	Thermostatic
36475	3647550	3647560	240	13.0	6-20P	Infinite
3647510	3647570	3647580	240	13.0	6-20P	Thermostatic

Note: HD wells have two-year warranty
 Note: Modular drop-ins cannot be canceled or returned



6-Well Hot Drop-Ins

- Overall dimensions: 81¼" x 26" (206.4 x 66 cm)
- Add "HD" to item number for marine-grade well



1000W STANDARD DRAIN	MANIFOLD DRAIN	MANIFOLD WITH AUTOFILL	VOLTAGE: AC	AMPS	PLUG	CONTROL
3640901	3640951	3640961	208-240	21.6-25	6-50P	Infinite
3640911	3640971	3640981	208-240	21.6-25	6-50P	Thermostatic

625W STANDARD DRAIN	MANIFOLD DRAIN	MANIFOLD WITH AUTOFILL	VOLTAGE: AC	AMPS	PLUG	CONTROL
36409	3640950	3640960	208	18.0	6-30P	Infinite
3640910	3640970	3640980	208	18.0	6-30P	Thermostatic
36476	3647650	3647660	240	15.6	6-20P	Infinite
3647610	3647670	3647680	240	15.6	6-20P	Thermostatic

Note: HD wells have two-year warranty
 Note: Modular drop-ins cannot be canceled or returned





Cold Drop-Ins

Cold drop-in models: choice of NSF 7, forced air, standard well or frost top designs

Recessed shoulder for NSF 7 models

Drip-free flange

Thick polyurethane foam insulation

1" (2.3 cm) integrated drain standard

Self-contained compressor (five-year warranty)

Cord and plug (120V)

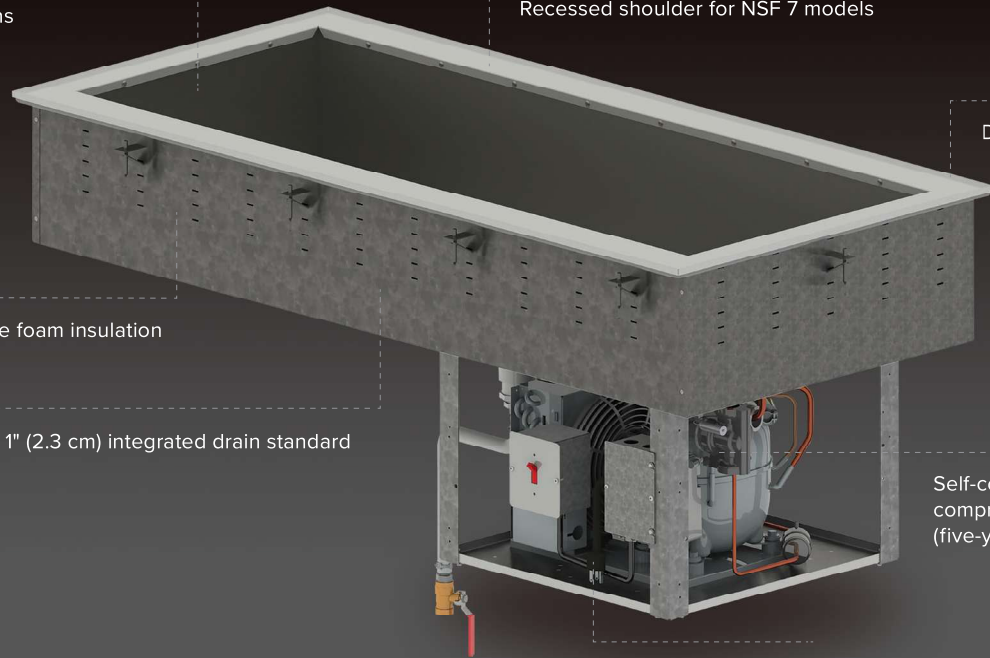

Nonrefrigerated Short Side Cold Pans

- 18-8 stainless steel construction
- 8" (20.3 cm) deep well
- Thick polyurethane foam insulation
- Full-perimeter drip edge contains spills and condensation
- 1" (2.5 cm) integrated drain standard
- Narrow space-saving design
- Sized for standard steam table pan sizes
- Drain plug included



ITEM #	PANS	OVERALL DIMENSIONS (W X D): IN (CM)
36654	Two	45 ⁷ / ₁₆ x 18 (115.4 x 45.79)
36657	Three	66 ⁷ / ₈ x 18 (170 x 45.79)
36660	Four	88 ¹ / ₄ x 18 (224.2 x 45.79)

Note: Modular drop-ins cannot be canceled or returned





Nonrefrigerated Cold Pans

- 18-8 stainless steel construction
- 8" (20.3 cm) deep well
- Thick polyurethane foam insulation
- Full-perimeter drip edge contains spills and condensation
- 1" (2.5 cm) integrated drain standard
- Drain plug included



ITEM #	DESCRIPTION	OVERALL DIMENSIONS (W X D): IN (CM)	INTERIOR LENGTH: IN (CM)
36491	1-pan	15 x 26 (38.1 x 66)	12 (30.5)
36450	2-pan	29 x 26 (73.7 x 66)	24¾ (62.9)
36451	3-pan	41½ x 26 (105.4 x 66)	37½ (95.3)
36452	4-pan	54¾ x 26 (139.1 x 66)	50¼ (127.6)
36453	5-pan	68 x 26 (172.7 x 66)	63 (160)
36454	6-pan	81¼ x 26 (206.4 x 66)	75¾ (192.4)

Note: Modular drop-ins cannot be canceled or returned



Refrigerated Short Side Drop-Ins

- Thick polyurethane foam insulation
- Display well 6⅝" (16.8 cm) deep
- Drain plug included
- Cold drop-ins are best used for holding periods up to four hours — for best performance, stainless steel containers are recommended

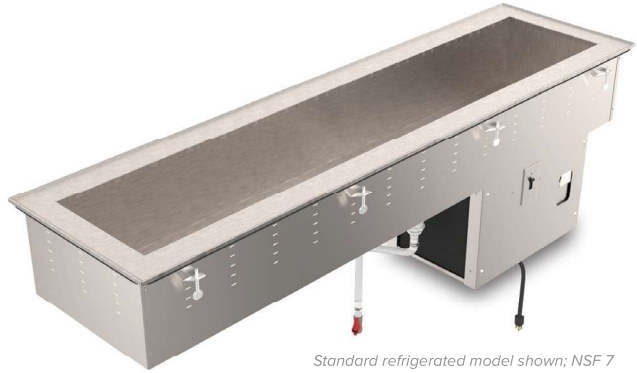

Standard refrigerated model shown; NSF 7 units feature recessed shoulders

ITEM #	DESCRIPTION	OVERALL DIMENSIONS (L X W X H): IN (CM)	INTERIOR LENGTH: IN (CM)	DISPLAY AREA: IN (CM)	COMPRESSOR	VOLTAGE: AC	AMPS	PLUG
REFRIGERATED SHORT SIDE DROP-INS								
FC-4CS-02120-R	2-pan	45⅞ x 18⅞ x 22⅜ (115.4 x 45.9 x 58)	40¾ (103.5)	40¾ x 11⅞ (103.5 x 30.2)	½ hp	120	3.8	5-15P
FC-4CS-03120-R	3-pan	66⅞ x 18⅞ x 22⅜ (170 x 45.9 x 58)	61½ (156.2)	61½ x 11⅞ (156.2 x 30.2)	¼ hp	120	4.9	5-15P
FC-4CS-04120-R	4-pan	88⅞ x 18⅞ x 22⅜ (224.3 x 45.9 x 58)	82¼ (209)	82¼ x 11⅞ (209 x 30.2)	¼ hp	120	4.9	5-15P
NSF 7 REFRIGERATED SHORT SIDE DROP-INS								
FC-4CS-02120-N	2-pan	45⅞ x 18⅞ x 22⅜ (115.4 x 45.9 x 58)	40¾ (103.5)	40¾ x 11⅞ (103.5 x 30.2)	¼ hp	120	4.9	5-15P
FC-4CS-03120-N	3-pan	66⅞ x 18⅞ x 22⅜ (170 x 45.9 x 58)	61½ (156.2)	61½ x 11⅞ (156.2 x 30.2)	¼ hp	120	4.9	5-15P
FC-4CS-04120-N	4-pan	88⅞ x 18⅞ x 22⅜ (224.3 x 45.9 x 58)	82¼ (209)	82¼ x 11⅞ (209 x 30.2)	½ hp	120	4.9	5-15P

Note: Modular drop-ins cannot be canceled or returned





Standard Refrigerated Cold Pan

- 8" (20.3 cm) deep well
- Thick polyurethane foam insulation
- Drain plug included
- Cold drop-ins are best used for holding periods up to four hours – for best performance, stainless steel containers are recommended

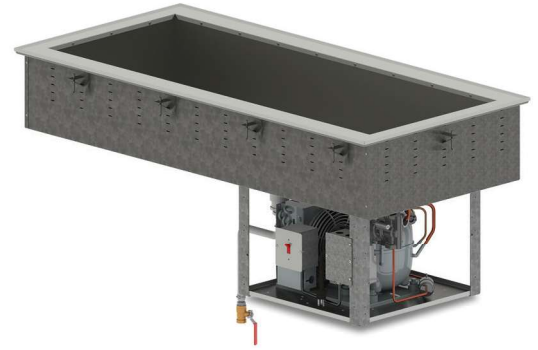

STANDARD ITEM #	REMOTE ITEM #**	DESCRIPTION	OVERALL DIMENSIONS (W X D): IN (CM)	INTERIOR LENGTH: IN (CM)	COMPRESSOR	VOLTAGE: AC	AMPS	PLUG
FC-4C-01120-R	36490R	1-pan	15 x 26 (38.1 x 66)	12 (30.5)	1/5 hp	120	3.8	5-15P
FC-4C-02120-R	36441R	2-pan	29 x 26 (73.7 x 66)	24 3/4 (62.9)	1/5 hp	120	3.8	5-15P
FC-4C-03120-R	36442R	3-pan	41 1/2 x 26 (105.4 x 66)	37 1/2 (95.3)	1/5 hp	120	3.8	5-15P
FC-4C-04120-R	36444R	4-pan	54 3/4 x 26 (139.1 x 66)	50 1/4 (127.6)	1/4 hp	120	4.9	5-15P
FC-4C-05120-R	36446R	5-pan	68 x 26 (172.7 x 66)	63 (160)	1/4 hp	120	4.9	5-15P
FC-4C-06120-R	36448R	6-pan	81 1/4 x 26 (206.4 x 66)	75 3/4 (192.4)	1/3 hp	120	7.2	5-20P

*With 3/8" (2.2 cm) corner radius

**Accessories available for remote installation. Remote units available but not shown; please reference spec sheet. Remote units do not include compressor.

Note: Modular drop-ins cannot be canceled or returned



NSF 7 Forced-Air Cold Drop-Ins

- Low-velocity airflow for even temperature
- Dual-sided airflow and intake for consistent chilling
- 1" recess to bring food closer to customer
- Must use templates and/or adapter bars
- Best performance with stainless steel pans



STANDARD ITEM #	DESCRIPTION	OVERALL DIMENSIONS (W X D): IN (CM)	INTERIOR LENGTH: IN (CM)	COMPRESSOR	VOLTAGE: AC	AMPS	PLUG
FC-4C-03120-FA	3-pan	41 1/2 x 26 (105.4 x 66)	40 3/4 (103.5)	1/3 hp	120	6	5-15P
FC-4C-04120-FA	4-pan	54 3/4 x 26 (139.1 x 66)	54 (137.2)	1/3 hp	120	6	5-15P

Note: Modular drop-ins cannot be canceled or returned





NSF 7 Refrigerated Cold Pans

- Shoulder is recessed 3" (7.6 cm)
- NSF 7 listed
- Display well 6⁵/₈" (16.8 cm) deep
- Drain plug included



STANDARD ITEM #	REMOTE ITEM #**	DESCRIPTION	OVERALL DIMENSIONS (D X W): IN (CM)	INTERIOR LENGTH: IN (CM)	COMPRESSOR	VOLTAGE: AC	AMPS	PLUG
FC-4C-01120-N	36456R	1-pan	18 x 26 (45.7 x 66)	12 (30.5)	1/5 hp	120	3.8	5-15P
FC-4C-02120-N	36429R	2-pan	29 x 26 (73.7 x 66)	24 ³ / ₄ (62.9)	1/4 hp	120	4.9	5-15P
FC-4C-03120-N	36430R	3-pan	41 ¹ / ₂ x 26 (105.4 x 66)	37 ¹ / ₂ (95.3)	1/4 hp	120	4.9	5-15P
FC-4C-04120-N	36434R	4-pan	54 ³ / ₄ x 26 (139.1 x 66)	50 ¹ / ₄ (127.6)	1/3 hp	120	7.2	5-20P
FC-4C-05120-N	36436R	5-pan	68 x 26 (172.7 x 66)	63 (160)	1/2 hp	120	11.0	5-20P
FC-4C-06120-N	36438R	6-pan	81 ¹ / ₄ x 26 (206.4 x 66)	75 ³ / ₄ (192.4)	1/2 hp	120	11.0	5-20P

Note: Modular drop-ins cannot be canceled or returned **Remote units available but not shown; please reference spec sheet. Remote units do not include compressor.



Refrigerated Frost Tops

- Recessed drip flange with integral drain for cleaner operation
- Display area flush with counter surface

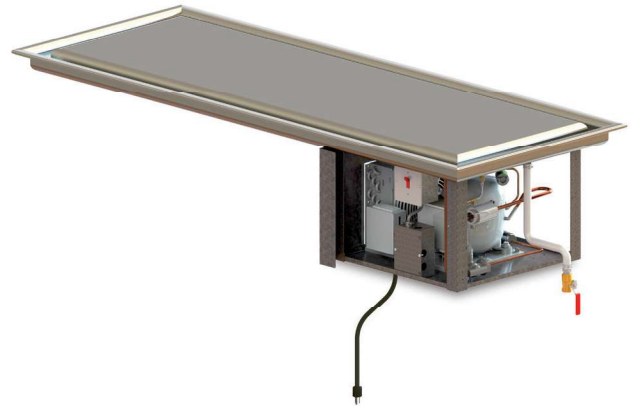

ITEM #	DESCRIPTION	OVERALL DIMENSIONS (W X D): IN (CM)	DISPLAY AREA LENGTH: IN (CM)	COMPRESSOR	VOLTAGE: AC	AMPS	PLUG
FC-4C-02120-F	2-pan	28 ¹ / ₄ x 26 (71.8 x 66)	22 ¹ / ₄ (56.5)	1/4 hp	120	4.9	5-15P
FC-4C-03120-F	3-pan	41 ¹ / ₂ x 26 (105.4 x 66)	35 ¹ / ₂ (90.2)	1/3 hp	120	5.9	5-15P
FC-4C-04120-F	4-pan	54 ³ / ₄ x 26 (139.1 x 66)	48 ³ / ₄ (123.8)	1/3 hp	120	5.9	5-15P
FC-4C-05120-F	5-pan	68 x 26 (172.7 x 66)	62 (157.5)	1/2 hp	120	12.9	5-20P
FC-4C-06120-F	6-pan	81 ¹ / ₄ x 26 (206.4 x 66)	75 ³ / ₄ (191.1)	1/2 hp	120	12.9	5-20P

Note: Modular drop-ins cannot be canceled or returned





Combination Hot/Cold Drop-Ins



- Versatile hot/cold drop-in unit gives you the ultimate in convenient serving options
- Controls wells individually for daypart flexibility
- Allows change from a cold salad bar to hot buffet or a hot/cold combination bar with the flip of a switch
- Wells pass NSF 4 and NSF 7 performance testing for open-top hot food holding and refrigerated buffet units; listed under NSF/ANSI 169 for special-purpose food equipment and devices
- Ships with cord and plug – no hard-wiring needed

ITEM #	DESCRIPTION	OVERALL DIMENSIONS: IN (CM)	VOLTAGE: AC	AMPS	PLUG
FC-6HC-01120-AD	1-well drop-in	18 ¹ / ₁₆ x 26 (45.9 x 66)	120	6	5-15P
FC-6HC-01208-AD	1-well drop-in auto manifold drain	18 ¹ / ₁₆ x 26 (45.9 x 66)	120/208-240	6	14-20P
FC-6HC-02120	2-well drop-in	41 ¹ / ₂ x 26 (105.4 x 66)	120	11.2	5-15P
FC-6HC-02120-AD	2-well drop-in auto manifold drain	41 ¹ / ₂ x 26 (105.4 x 66)	120	11.2	5-15P
FC-6HC-02208	2-well drop-in	41 ¹ / ₂ x 26 (105.4 x 66)	120/208-240	8.6	14-20P
FC-6HC-02208-AD	2-well drop-in auto manifold drain	41 ¹ / ₂ x 26 (105.4 x 66)	120/208-240	8.6	14-20P
FC-6HC-03120	3-well drop-in	54 ³ / ₄ x 26 (139.1 x 66)	120	16	5-20P
FC-6HC-03120-AD	3-well drop-in auto manifold drain	54 ³ / ₄ x 26 (139.1 x 66)	120	16	5-20P
FC-6HC-03208-AD	3-well drop-in	54 ³ / ₄ x 26 (139.1 x 66)	120/208-240	11.2	14-20P
FC-6HC-03208	3-well drop-in auto manifold drain	54 ³ / ₄ x 26 (139.1 x 66)	120/208-240	11.2	14-20P
FC-6HC-04208	4-well drop-in	68 x 26 (172.7 x 66)	120/208-240	14	14-20P
FC-6HC-04208-AD	4-well drop-in auto manifold drain	68 x 26 (172.7 x 66)	120/208-240	14	14-20P

Note: Modular drop-ins cannot be canceled or returned





Induction Wok Range

- High efficiency of induction, with gaslike performance
- 100 power settings for precise cooking control
- Turbo button for immediate heat
- Simple digital power level controls

Stainless steel template for drop-in induction wok range



ITEM #	DESCRIPTION	DIMENSIONS (W X D X H): IN (CM)	VOLTAGE: AC	KW	AMPS	CASE LOT
6958301	Countertop induction wok range*	17 x 20 ¹ / ₈ x 8 ³ / ₁₆ (43.2 x 51 x 21)	208-240	3-3.5	14.6	1
58814	Carbon steel wok pan	Pan diameter 14 (35.6) x height 3 ⁷ / ₈ (9.9)	–	–	–	1
69584	Stainless steel template for drop-in induction wok range	22 x 19 x ³ / ₄ (55.9 x 48.3 x 1.9)	–	–	–	1

*Ships with carbon steel wok pan



Ultra Series Drop-In Induction Ranges

DESIGNED FOR LARGE-VOLUME AND HEAVY-DUTY USAGE

- 100 power settings for precise cooking control
- Sensitive low-end control for cooking delicate sauces, cremes and chocolates
- 90% efficiency versus 40% for gas stoves
- 6-foot (183 cm) cord and plug; 3-foot (91.4 cm) remote control cord



ITEM #	DESCRIPTION	MAX PAN SIZE: IN (CM)	DIMENSIONS (W X D X H): IN (CM)	VOLTAGE: AC	MAX KW	AMPS	PLUG	CASE LOT
69505**	Drop-in	14 (35.6)	17 ³ / ₈ x 16 ¹ / ₂ x 4 ³ / ₄ (44.1 x 41.9 x 12)	208/240	3.5	14.6	6-20P	1
69508**	Dual-hob drop-in front to back	12 (30.5)	17 ³ / ₈ x 27 ⁷ / ₈ x 5 ¹ / ₈ (44.1 x 70.8 x 13)	208/240	3.5*	29.2	6-50P	1

69505/69508 control box cutout dimensions: 7¹/₄" x 3³/₈" (18.4 x 9.8 cm) Note: 1 control per hob



Professional Series Drop-In Induction Ranges

DESIGNED FOR SAUTÉ, SAUCE POTS, AND SMALL STOCKPOTS

- 100 settings for precise cooking control – set to power level or temperature setting
- Continuous-duty induction circuitry for nonstop cooking
- Firewall-protected circuitry with oversized fans and 18-gauge heavy-duty 18-8 stainless steel casing
- 1- to 180-minute timer – unit shuts off at end of cycle



ITEM #	DESCRIPTION	MAX PAN SIZE: IN (CM)	DIMENSIONS (W X D X H): IN (CM)	VOLTAGE: AC	MAX KW	AMPS	PLUG	CASE LOT
69524*	Dual-hob drop-in front to back	12 (30.5)	17 ³ / ₈ x 27 ⁷ / ₈ x 4 ³ / ₄ (44.1 x 70.8 x 12.1)	208/240	2.9 per hob	24.2	6-30P	1
69521*	Single-hob drop-in	14 (35.6)	17 ³ / ₈ x 16 ³ / ₄ x 4 ¹ / ₂ (44.8 x 42.5 x 11.4)	208/240	2.9	12.1	6-20P	1

*69521 and 69524 control box cutout dimensions: 7¹/₄" x 3³/₈" (18.4 x 9.8 cm)





Mirage® Drop-In Induction Ranges

DESIGNED FOR LIGHT COMMERCIAL SAUTÉ AND WARMING STATIONS

- Cutting-edge dial control with high-speed power and temperature level adjustment – includes 1- to 180-minute timer function
- Bright LED digital readout is easy to see
- Temperature memory – powers up to the last-used temperature setting



ITEM #	DESCRIPTION	MAX PAN SIZE: IN (CM)	DIMENSIONS (L X W X H: IN (CM))	VOLTAGE: AC	KW	AMPS	PLUG
RANGES							
59501	US	14 (35.6)	14½ x 12½ x 2⅞ (36.8 x 31.8 x 7.3)	120	1.4	12	5-15P
59601	Europe	14 (35.6)	14½ x 12½ x 2⅞ (36.8 x 31.8 x 7.3)	230	1.8	7.8	Schuko
59602	UK	14 (35.6)	14½ x 12½ x 2⅞ (36.8 x 31.8 x 7.3)	230	1.8	7.8	UK
59603	China	14 (35.6)	14½ x 12½ x 2⅞ (36.8 x 31.8 x 7.3)	230	1.8	7.8	China
59605	Australia	14 (35.6)	14½ x 12½ x 2⅞ (36.8 x 31.8 x 7.3)	230	1.8	2.8	AU2-15R
WARMERS*							
5950145	US	14 (35.6)	14½ x 12½ x 2⅞ (36.8 x 31.8 x 7.3)	120	.45	3.8	5-15P
5950170	US	14 (35.6)	14½ x 12½ x 2⅞ (36.8 x 31.8 x 7.3)	120	.7	5.8	5-15P
59641	Europe	14 (35.6)	14½ x 12½ x 2⅞ (36.8 x 31.8 x 7.3)	230	.65	2.8	Schuko
59642	UK	14 (35.6)	14½ x 12½ x 2⅞ (36.8 x 31.8 x 7.3)	230	.65	2.8	UK
59643	China	14 (35.6)	14½ x 12½ x 2⅞ (36.8 x 31.8 x 7.3)	230	.65	2.8	China
59645	Australia	14 (35.6)	14½ x 12½ x 2⅞ (36.8 x 31.8 x 7.3)	230	.65	2.8	AU2-15R

*Warming unit only – not a cooking range



*International models only

Mirage® Buffet Drop-In Induction Warmers

- Fewer cords – connect up to three units together with interconnect cords
- Subtle, low-profile, attractive design coordinates with any serving setup
- Low wattage to keep food warm during serving
- Tempered, black glass top
- Touch control, four power settings



ITEM #	DESCRIPTION	DIMENSIONS: (W X D X H): IN (CM)	VOLTAGE: AC	WATTS	AMPS	PLUG	CASE LOT
59502DW	16" x 16" drop-in induction warmer – US	16 x 16 x 3⅞ (40.6 x 40.6 x 8)	120	300	2.5	NEMA 5-15P	1
59508DW	Full-size drop-in induction warmer – US	23 x 16 x 3⅞ (58.4 x 40.6 x 7.78)	120	375	3.15	NEMA 5-15P	1
59508DW*	Full-size drop-in induction warmer – International	23 x 16 x 3⅞ (58.4 x 40.6 x 7.78)	230	375	3.15	**	1

*International models: Add required two-digit suffix to item number – Schuko (02), UK (03), China (04), Australia (05)





NEW

FlexVent™ Versatile Slide-In

WITH DOWNDRAFT VENT SYSTEM AND FIRE SUPPRESSION



Interchange cord-and-plug cooking equipment; slide-in unit is not designed for use with gas equipment



RECOMMENDED EQUIPMENT

For a complete list of recommended equipment, visit vollrathfoodservice.com/flexventrelatedproducts.

ITEM #	DIMENSIONS (W X H X D): IN (CM)	APPLIANCE AREA (D X W): IN (CM)	VOLTAGE: AC	HZ	WATTS	AMPS	SHELF WEIGHT LIMIT*
FC-6DV-36	53½ x 36¾ x 35½ (135.9 x 93.3 x 89.2)	18¼ x 35 (46.4 x 88.9)	120	60	420	3.4	120 LB
DESCRIPTION	VOLTAGE: AC	HZ	WATTS	AMPS	SHELF WEIGHT LIMIT*		
Max. Configurable Appliance Load*	120/208-240	60	7200	30	120 LB		

*Total maximum weight limit for the shelf is 120 pounds, evenly distributed. Compliance with this limit is required for the safe operation of FlexVent.





Fully self-contained downdraft recirculating vent and fire suppression system with UL 710B certification eliminates the need for bulky exhaust hoods



Fabricator installed outlets; unit ships with blank panel

Adjustable shelf fulfills a variety of height requirements for equipment, ergonomic needs, and health code requirements and enables the proper function of the fire suppression system



Fits seamlessly to custom serving lines for an aesthetically pleasing look



Sinks

Drop-In Sinks

- Available in heavyweight 20-gauge and standard-weight 22-gauge
- Type 304 stainless steel
- Self-rimming or flat rim
- One-piece drawn bowl
- Satin finish bowl with brushed finish flange

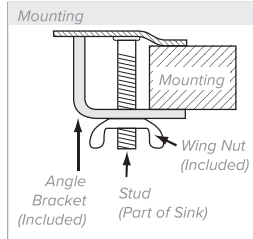

ITEM #	DESCRIPTION	GAUGE	OVERALL DIMENSIONS (W X L): IN (CM)	BOWL SIZE (W X L X D): IN (CM)	DRAIN DIA: IN (CM)	CASE LOT
SELF-RIMMING SINKS						
212560*	Single-bowl sink	22	13 x 15¾ (33 x 40)	11 x 13¼ x 6 (27.9 x 33.6 x 15.2)	2 (5.1)	1
101-1-1	Single-bowl sink	20	13 x 17 (33 x 43.2)	10 x 14 x 10 (25.4 x 35.6 x 25.4)	3½ (8.9)	1
101-1-2	Single-bowl sink	20	13 x 17 (33 x 43.2)	10 x 14 x 10 (25.4 x 35.6 x 25.4)	2 (5.1)	1
229-1	Single-bowl sink	20	22 x 19 (55.9 x 48.3)	16 x 18½ x 6½ (40.6 x 47 x 16.5)	3½ (8.9)	1
102-1-1	Double-bowl sink	20	25 x 17 (63.5 x 43.2)	10 x 14 x 10 (25.4 x 35.6 x 25.4)	3½ (8.9)	4
102-1-2	Double-bowl sink	20	25 x 17 (63.5 x 43.2)	10 x 14 x 10 (25.4 x 35.6 x 25.4)	2 (5.1)	4
FLAT-RIM SINKS						
131-8	Single-bowl sink	22	13 x 10¾ (33 x 27.3)	9¾ x 11¾ x 4 (23.8 x 29.8 x 10.2)	2 (5.1)	6
131-9	Single-bowl sink	22	13 x 10¾ (33 x 27.3)	9¾ x 11¾ x 6½ (23.8 x 29.8 x 16.5)	2 (5.1)	6

*CSA certified



*NSF and CSA apply to sink bowl only

Round Sinks

- Type 304 stainless steel
- Buffed-bead stainless steel
- Self-rimming
- Top or bottom mount
- Positive drain (201250 only)
- 2" drain diameter
- Stud mount
- Mounting brackets included
- Brushed finish flange
- Satin finish bowl

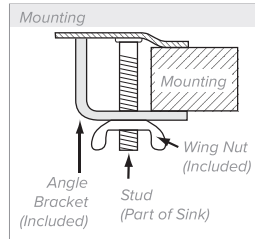

ITEM #	DESCRIPTION	GAUGE	OVERALL DIAMETER: IN (CM)	BOWL SIZE (DIA X D): IN (CM)	CASE LOT
201250*	Sink	22	12 ¹⁵ / ₁₆ (32.9)	10¾ x 4½ (27.3 x 11.4)	5
201260	Sink with straight sides	20	12¼ (31.1)	10¾ x 5¼ (26.2 x 13.3)	1

*Only 201250 is CSA





Undermount/Welded-In Sinks

- Available in heavyweight 20-gauge and extra-heavyweight 18-gauge
- Type 304 stainless steel
- 1" flange
- Satin finish bowl with brushed finish flange
- One-piece drawn bowl



9101-1



12122-1

ITEM #	DESCRIPTION	OVERALL DIMENSIONS (W X L): IN (CM)	BOWL SIZE (W X L X D): IN (CM)	DRAIN DIA: IN (CM)	CASE LOT
HEAVYWEIGHT 20-GAUGE					
9101-1	Single-bowl sink	11 x 16 (27.9 x 40.6)	9 x 14 x 10 (22.9 x 35.6 x 25.4)	3½ (8.9)	4
10101-0*	Single-bowl sink	12 x 16 (30.5 x 40.6)	10 x 14 x 10 (25.4 x 35.6 x 25.4)	–	4
10101-1P	Single-bowl sink	12 x 16 (30.5 x 40.6)	10 x 14 x 10 (25.4 x 35.6 x 25.4)	3½ (8.9)	4
12101-1	Single-bowl sink	14 x 16 (35.6 x 40.6)	12 x 14 x 10 (30.5 x 35.6 x 25.4)	3½ (8.9)	2
9102-1	Double-bowl sink	21 x 16 (53.3 x 40.6)	9 x 14 x 10 (22.9 x 35.6 x 25.4)	3½ (8.9)	1
10102-1	Double-bowl sink	23 x 16 (58.4 x 40.6)	10 x 14 x 10 (25.4 x 35.6 x 25.4)	3½ (8.9)	1
12102-1	Double-bowl sink	27 x 16 (68.6 x 40.6)	12 x 14 x 10 (30.5 x 35.6 x 25.4)	3½ (8.9)	1
9103-1	Triple-bowl sink	31 x 16 (78.7 x 40.6)	9 x 14 x 10 (22.9 x 35.6 x 25.4)	3½ (8.9)	1
10103-1	Triple-bowl sink	34 x 16 (86.4 x 40.6)	10 x 14 x 10 (25.4 x 35.6 x 25.4)	3½ (8.9)	1
12103-1	Triple-bowl sink	40 x 16 (101.6 x 40.6)	12 x 14 x 10 (30.5 x 35.6 x 25.4)	3½ (8.9)	1
SUPER-HEAVYWEIGHT 18-GAUGE					
12121-1	Single-bowl sink	14 x 16 (35.6 x 40.6)	12 x 14 x 12 (30.5 x 35.6 x 30.5)	3½ (8.9)	2
16141-1	Single-bowl sink	18 x 21 (45.7 x 53.3)	16 x 19 x 14 (40.6 x 48.3 x 35.6)	3½ (8.9)	1
12122-1	Double-bowl sink	27 x 16 (68.6 x 40.6)	12 x 14 x 12 (30.5 x 35.6 x 30.5)	3½ (8.9)	1
12123-1	Triple-bowl sink	40 x 16 (101.6 x 40.6)	12 x 14 x 12 (30.5 x 35.6 x 30.5)	3½ (8.9)	1
12123-2	Triple-bowl sink	40 x 16 (101.6 x 40.6)	12 x 14 x 12 (30.5 x 35.6 x 30.5)	2 (5.1)	1

*Solid bowl. No drain.



Vending Cart Sinks

- Standard-weight 22-gauge
- Type 304 stainless steel
- Satin finish bowl with brushed finish flange
- Self-rimming
- Stud mounting with mounting brackets included
- 2" drain
- Sound deadening

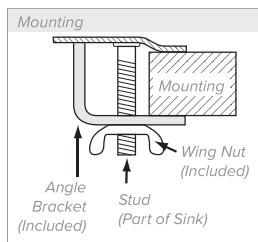

12065-2



12065-3

ITEM #	DESCRIPTION	OVERALL DIMENSIONS (W X L): IN (CM)	BOWL SIZE (W X L X D): IN (CM)	CASE LOT
12065-2	Double-bowl sink	17 x 13 (43.2 x 33.0)	6½ x 12½ x 5 (15.6 x 30.8 x 12.7)	1
12065-3	Triple-bowl sink	21 x 13 (53.3 x 33.0)	6½ x 12½ x 5 (15.6 x 30.8 x 12.7)	1





Bar Sinks

- Heavyweight 20-gauge
- Type 304 stainless steel
- Self-rimming
- Satin finish bowl with brushed finish flange
- One-piece drawn bowl
- Stud mounting with mounting brackets included
- Positive drain – 3½" diameter
- Optional splash mounted AB1953 lead-free compliant faucet – full brass body
- Two holes on 4" centers



K1734-C

ITEM #	DESCRIPTION	OVERALL DIMENSIONS (W X L): IN (CM)	BOWL SIZE (W X L X D): IN (CM)	CASE LOT
155-4	Sink	15 x 15 (38.1 x 38.1)	11 x 10 x 6¾ (28 x 25.4 x 15.7)	1
1554-C	Sink with strainer	15 x 15 (38.1 x 38.1)	11 x 10 x 6¾ (28 x 25.4 x 15.7)	1
K1554-C	Sink with strainer and gooseneck faucet	15 x 15 (38.1 x 38.1)	11 x 10 x 6¾ (28 x 25.4 x 15.7)	1
1551*	Sink for use with electronic mixing faucet (not included)	15 x 15 (38.1 x 38.1)	11 x 10 x 6¾ (28 x 25.4 x 15.7)	1
173-4-2	Sink	13 x 17 (33 x 43.2)	10 x 11 x 6¾ (25.4 x 28 x 15.7)	1
1734-C	Sink with strainer	13 x 17 (33 x 43.2)	10 x 11 x 6¾ (25.4 x 28 x 15.7)	1
K1734-C	Sink with strainer and gooseneck faucet	13 x 17 (33 x 43.2)	10 x 11 x 6¾ (25.4 x 28 x 15.7)	1

*Has single hole



*NSF and CSA apply to sink bowl only

ACCESSORIES		CASE LOT
2612	Gooseneck faucet, 4" (10.2 cm) centers, 7½" (19.1 cm) high	1
2005	Repair kit for 2612 faucet	1
7400P*	Strainer for 3½" (8.9 cm) drains	1

Waste Chutes

- Stainless steel
- Won't chip, break, or corrode and have an easy-to-clean finish
- Strong rounded collar is smooth and provides a positive fit into any countertop



E6WC02



E9WC02



3Y0505



8Y802



120Y02

ITEM #	RIM DIMENSIONS (W X D X H): IN (CM)	CASE LOT
RECTANGULAR WASTE CHUTES		
E6WC02	Sixth size – 6.875 x 6.25 x 2	6
E9WC02	Ninth size – 6.875 x 4.25 x 2	12

ITEM #	RIM DIMENSIONS (DIA X D): IN (CM)	CASE LOT
ROUND WASTE CHUTES		
1Y402	4¾ x 2 (11.6 x 5.1)	12
3Y0502	6¾ x 2 (16.7 x 5.1)	6
3Y0505	6¾ x 5 (16.7 x 12.7)	8
8Y802	8²³⁄₂ x 2 (22.1 x 5.1)	6
120Y02	11 x 2 (27.9 x 5.1)	6





Wall-Mount Hand Sinks

- Heavyweight 20-gauge
- Optional splash mounted AB1953 lead-free compliant faucet – full brass body
- Type 304 stainless steel
- Brushed finish flange
- High backsplash
- One-piece drawn bowl
- Positive drain – 2" diameter
- Two holes on 4" center



1410CS



141-O

ITEM #	DESCRIPTION	OVERALL DIMENSIONS (W X L): IN (CM)	BOWL SIZE (W X L X D): IN (CM)	CASE LOT
141-O	Sink	17 x 15 (43.2 x 38.1)	13 ⁹ / ₁₆ x 9 ⁹ / ₁₆ x 5 ¹ / ₂ (34.4 x 24.3 x 14)	1
141-OC	Sink with strainer	17 x 15 (43.2 x 38.1)	13 ⁹ / ₁₆ x 9 ⁹ / ₁₆ x 5 ¹ / ₂ (34.4 x 24.3 x 14)	1
K1410-C	Sink with strainer and gooseneck faucet	17 x 15 (43.2 x 38.1)	13 ⁹ / ₁₆ x 9 ⁹ / ₁₆ x 5 ¹ / ₂ (34.4 x 24.3 x 14)	1
K1410-CP	Sink with strainer, gooseneck faucet, and p-trap	17 x 15 (43.2 x 38.1)	13 ⁹ / ₁₆ x 9 ⁹ / ₁₆ x 5 ¹ / ₂ (34.4 x 24.3 x 14)	1
1411*	Sink for use with electronic mixing faucet (not included)	17 x 15 (43.2 x 38.1)	13 ⁹ / ₁₆ x 9 ⁹ / ₁₆ x 5 ¹ / ₂ (34.4 x 24.3 x 14)	1
WITH SPLASH GUARD SIDES				
1410-O	Sink with splash guards	17 x 15 (43.2 x 38.1)	13 ⁹ / ₁₆ x 9 ⁹ / ₁₆ x 5 ¹ / ₂ (34.4 x 24.3 x 14)	1
1410CS	Sink with splash guards and strainer	17 x 15 (43.2 x 38.1)	13 ⁹ / ₁₆ x 9 ⁹ / ₁₆ x 5 ¹ / ₂ (34.4 x 24.3 x 14)	1
K1410CS	Sink with splash guards, strainer, and gooseneck faucet	17 x 15 (43.2 x 38.1)	13 ⁹ / ₁₆ x 9 ⁹ / ₁₆ x 5 ¹ / ₂ (34.4 x 24.3 x 14)	1

*1411 has single hole



*NSF and CSA apply to sink bowl only



2613



7466



1410T



PRO_K1410-CP

SINK DIMENSION KEY

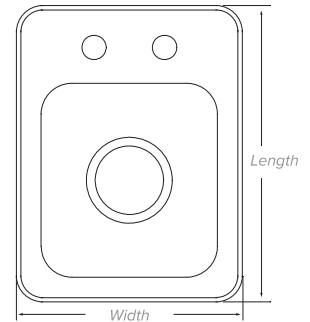

ACCESSORIES		CASE LOT
2613*	Gooseneck faucet – AB1953 lead-free compliant	1
2004*	Repair kit for 2613 faucet	1
7466*	Strainer for 2" (5.1) drain	1
1410T*	4" (10.2) flanged tail piece	24

*Imported item

Knock Box

- Stainless steel
- One-sixth size, 4" deep
- Rubber-coated knock bar
- Includes attachable rubber feet



ITEM #	OVERALL DIMENSIONS (W X D X H): IN (CM)	RIM DIMENSIONS (W X D X H): IN (CM)	CAPACITY: QT	CASE LOT
E06064-KB	5.9 x 5.4 x 4 (15 x 13.7 x 10.2)	6 ⁷ / ₈ x 6 ³ / ₈ x 4 (17.2 x 16.2 x 10.2)	1 ⁷ / ₈	1





Dispensers & Organizers

- Make the most of valuable retail space
- Mounts flush into food counter
- Durable construction



LidSaver® 3 Dispensers

- Fewer wasted lids adds up to more savings
- Requires less labor for cleanup
- Helps eliminate contamination from excess handling
- Keeps operations clean and tidy, addressing major consumer concerns about health and well-being
- Simple-to-use design allows customers to fill beverages and grab a lid using only one hand
- Dispenses soda, coffee, and domed lids from 1¾" to 4¾" (4.4 to 12.1 cm)



LS031B-__(lid code)

ITEM #	DESCRIPTION	DIMENSIONS (L X W X H): IN (CM)	FOR LIDS WITH RIM DIAMETER: IN (CM)	CASE LOT
LS031B-(lid code)**	Horizontal mount with black housing	26⅜ x 5¾ x 6⅞ (67.1 x 14.7 x 15.5)	3¼ - 4 (8.3 - 10.2)	1
LS03PB-(lid code)**	Horizontal mount with black housing	26⅜ x 5⅞ x 6½ (67.1 x 15 x 16.5)	4⅞ - 4¾ (10.3 - 12.1)	1
LS031VB-(lid code)**	Vertical mount with black faceplate	26⅜ x 5⅞ x 6½ (67.1 x 15 x 16.5)	3¼ - 4 (8.3 - 10.2)	1
LS03PVB-(lid code)**	Vertical mount with black faceplate	26⅜ x 5⅞ x 6½ (67.1 x 15 x 16.5)	4⅞ - 4¾ (10.3 - 12.1)	1
LS03IS18B-(lid code)**	Shallow 18" horizontal mount, black faceplate	20⅞ x 5⅞ x 6½ (67.1 x 15 x 16.5)	3¼ - 4 (8.3 - 10.2)	1
LS03PS18B-(lid code)**	Shallow 18" horizontal mount, black faceplate	20⅞ x 5⅞ x 6½ (67.1 x 15 x 16.5)	4⅞ - 4¾ (10.3 - 12.1)	1

To complete item number, visit vollrathfoodservice.com to use the LidSaver 3 online configurator **NSF certified



LidSaver® 3 Mini

- Ideal for condiment cups and lids
- Smaller footprint takes up less valuable counter space
- In-counter models can mount horizontally or vertically



LS03MS18B-__(lid code)

ITEM #	DESCRIPTION	DIMENSIONS (W X H): IN (CM)	ACCOMMODATES CUPS/LIDS WITH RIM** DIAMETER: IN (CM)	CASE LOT
LS03MS18B-(lid code)*	In-counter, horizontal mount, 18" (45.7 cm) L tube	4⅞ x 5⅞ (12.5 x 14.3)	1¾-3¼ (4.4-8.3)	1
LS03MVS18B-(lid code)*	In-counter, vertical mount, 18" (45.7 cm) L tube	4⅞ x 5⅞ (12.5 x 14.3)	1¾-3¼ (4.4-8.3)	1

*LidSaver dispensers are NSF certified **Max rim height 1⅞" (4.8 cm)
To complete item number, visit vollrathfoodservice.com to use the LidSaver 3 online configurator





Cup Dispensers

- Plastic dispensers
- Molded silicone gasket for easy cup release
- Easy attachable collar
- Durable construction
- Four gaskets come with each unit



INC-80

ITEM #	DESCRIPTION	DIMENSIONS (L X W): IN (CM)	ACCOMMODATES CUPS WITH RIM DIAMETER: IN (CM)	CASE LOT
INC-80	Gasket-style cup dispenser, 23" (58.4 cm) L	24 ³ / ₈ x 6 ¹ / ₂ (62.2 x 16.5)	2 ¹ / ₄ - 4 ³ / ₄ (5.7 - 12.1)	1
INC-80S18	Gasket-style cup dispenser, 18" (45.7 cm) L	19 ¹ / ₄ x 6 ¹ / ₂ (49.5 x 16.5)	2 ¹ / ₄ - 4 ³ / ₄ (5.7 - 12.1)	1

*Additional models and cabinets available at vollrathfoodservice.com



Stainless Steel Cup Dispensers

- Each unit comes with two springs – light spring for foam cups
- Stainless steel grips ensure one-at-a-time dispensing



CADJ-3

ITEM #	DESCRIPTION	DIMENSIONS (L X W): IN (CM)	ACCOMMODATES CUPS WITH RIM DIAMETER: IN (CM)	CASE LOT
CADJ-1	In-counter adjustable stainless steel cup dispenser, 22"	22 x 5.4 (55.9 x 13.7)	2 ¹ / ₂ -3 ¹ / ₂ (6.4-8.9)	1
CADJ-2	In-counter adjustable stainless steel cup dispenser, 22"	22 x 5.4 (55.9 x 13.7)	3-3 ³ / ₈ (7.6-9.8)	1
CADJ-3	In-counter adjustable stainless steel cup dispenser, 22"	22 x 5.4 (55.9 x 13.7)	3-4 ⁵ / ₈ (7.6-11.7)	1
CADJ-4	In-counter adjustable stainless steel cup dispenser, 22"	22 x 5.4 (55.9 x 13.7)	4 ¹ / ₂ -5 ¹ / ₄ (11.4-13.3)	1

*Additional models and cabinets available at vollrathfoodservice.com



Wall-Mount LidSaver® and Cup Dispensers



C1VW

1VW-A

ITEM #*	DESCRIPTION	DIMENSIONS (H X W X L): IN (CM)	CASE LOT
C1VW-(LID CODE)	Vertical LidSaver	7 ¹ / ₈ x 7 ³ / ₈ x 25 ¹ / ₄ (18.1 x 18.7 x 64.1)	1
1VW-A	Gasket-style vertical cup dispenser INC-80	7 ¹ / ₈ x 7 ³ / ₈ x 25 ¹ / ₄ (18.1 x 18.7 x 64.1)	1

*Not a complete item number – visit online configurator to determine complete item number. LidSavers are lid specific, and lid manufacturer and part number must be supplied when ordering LidSaver.





Flush-Mount Dispensers

- Make the most of valuable retail space
- Mounts flush into food counter
- Constructed with virtually indestructible black thermoplastic
- Napkin dispensers are spring-loaded for continuous dispensing



ITEM #	DESCRIPTION	ACCOMMODATES	DIMENSIONS (W X H X D): IN (CM)	CUTOUT DIMENSIONS (W X H): IN (CM)	CASE LOT
FMN-1	Napkin dispenser, 5" H x 6½" W (12.7 x 16.5 cm), folded napkin	90	8½ x 6¼ x 5⅝ (21.6 x 15.9 x 13.7)	7⅞ x 5⅞ (19.2 x 13.5)	1
FMHVN-1	Napkin dispenser, high volume, 3½ x 6½ (8.9 x 15.2 cm), folded napkin	500	7⅞ x 8½ x 19½ (18.1 x 21.6 x 49.5)	6⅜ x 7⅝ (15.7 x 19.3)	1
FML-1	1-column lid holder, horizontal or vertical	—	6½ x 7¼ x 5⅝ (16.5 x 18.4 x 13.7)	5⅞ x 6⅞ (14.1 x 16)	1
FML-2V	2-column lid holder, vertical	—	6½ x 13⅞ x 5⅝ (16.5 x 34.1 x 13.7)	5⅞ x 12½ (14.1 x 31.7)	1
FML-3V	3-column lid holder, vertical	—	6½ x 19⅜ x 5⅝ (16.5 x 49.2 x 13.7)	5⅞ x 18⅞ (14.1 x 46.8)	1
FML-4V	4-column lid holder, vertical	—	6½ x 25½ x 5⅝ (16.5 x 64.8 x 13.7)	5⅞ x 24⅞ (14.1 x 62.3)	1
FML-2	2-column lid holder, horizontal	—	11 x 7¼ x 5⅝ (27.9 x 18.4 x 13.7)	10⅞ x 6⅞ (25.5 x 16)	1
FML-3	3-column lid holder, horizontal	—	16 x 7¼ x 5⅝ (40.6 x 18.4 x 13.7)	15⅞ x 6⅞ (38.2 x 16)	1
FML-4VS	4-column lid and 1- straw holder, vertical	—	6½ x 31½ x 13 (16.5 x 80 x 33)	5⅞ x 30⅞ (14.1 x 66.6)	1
FMDL-2V	2-stack dome lid holder, vertical	—	6¾ x 13⅞ x 12 (17.1 x 34 x 20.5)	5⅞ x 12½ (14.1 x 31.7)	1
FMDL-3H	3-stack dome lid holder, horizontal	—	18⅞ x 8⅞ x 10½ (48 x 20.4 x 26.6)	17⅞ x 7⅞ (45.4 x 16.1)	1
FMDL-3V	3-stack dome lid holder, vertical	—	6¾ x 18⅞ x 13 (17.1 x 47.9 x 33.7)	5⅞ x 18 (14.9 x 45.7)	1
FMS-3	Wrapped straw holder, 8-10" straws	—	6½ x 7½ x 7½ (16.5 x 19.1 x 19.1)	5⅞ x 6⅞ (14.2 x 16.1)	1
FMS-4	Wrapped straw holder, 10-12" straws	—	6½ x 7½ x 13 (16.5 x 19.1 x 33)	5⅞ x 6⅞ (14.2 x 16.1)	1
FMS-5	Stir stick holder	—	6½ x 7½ x 5⅞ (16.5 x 19.1 x 14.9)	5⅞ x 6⅞ (14.2 x 16.1)	1
FMT-1	Waxed tissue dispenser, two-box design	—	8½ x 8½ x 3½ (21.6 x 21.6 x 8.9)	7⅞ x 7⅞ (18.5 x 17.9)	1
FMS-6	"T" shaped wrapped straw dispenser. Holds 200 straws.	8 L (20.3)	10⅞ x 4⅞ x 7⅞ (26.8 x 12.2 x 18.6)	9⅞ x 5⅞ (23.2 x 14.6)	
FMS-7	Unwrapped straw dispenser. Dispenses one straw at a time. Holds 200 straws.	0.23 (0.58) to 0.265 (0.67) diameter and 7½ to 8¾ (19.1 to 22.2) L	10⅞ x 4½ x 7⅞ (26.8 x 11.4 x 18.7)	9½ x 6⅞ (24.1 x 15.6)	
FMF-2	Flatware or condiment holder – comes with 2- #52633	—	12⅞ x 6⅞ x 7½ (30.8 x 17.5 x 19.1)	11⅞ x 6¾ (28.9 x 17.1)	
FMF-3	Flatware holder – comes with 3- #52633	—	17⅞ x 6⅞ x 7½ (44.8 x 17.5 x 19.1)	17 x 6¾ (43.2 x 17.1)	





Trash Receptacle Doors

- Doors mount flush into counter
- Quality imprinted image
- Icon clearly indicates purpose
- MTS-1 units come with a spring for vertical or horizontal flush-mount



MT-2

ITEM #	DESCRIPTION	DIMENSIONS (W X H X D): IN (CM)	CUTOUT DIMENSIONS (W X H): IN (CM)	CASE LOT
MT-1	Small, vertical flush-mount	10 ⁵ / ₈ x 7 ¹ / ₂ x 2 (27 x 19.1 x 5.7)	9 ¹ / ₁₆ x 6 ⁹ / ₁₆ (24.6 x 16.6)	1
MT-1.5	Medium, flush-mount	13 x 7 ¹ / ₂ x 2 (33.7 x 19.1 x 5.7)	12 ⁵ / ₁₆ x 6 ⁹ / ₁₆ (31.2 x 16.6)	1
MTS-1	Small with spring for vertical or horizontal flush-mount	10 ⁵ / ₈ x 7 ¹ / ₂ x 2 (27 x 19.1 x 5.7)	9 ¹ / ₁₆ x 6 ⁹ / ₁₆ (24.6 x 16.6)	1
MT-2	Large, vertical flush-mount	17 ⁵ / ₈ x 7 ¹ / ₂ x 2 (44.8 x 19.1 x 5.7)	16 ¹ / ₁₆ x 6 ⁹ / ₁₆ (42.3 x 16.6)	1



ModuServ® Dispensers

- Mounts flush into counters
- Ultimate flexibility – easy to modify in endless configurations
- Clear faceplate secures components in place
- Components sold separately
- Tough, impact-resistant thermoplastic
- No tools required



ITEM #	DESCRIPTION	DIMENSIONS (W X H X D): IN (CM)	CASE LOT
MS-2A	Stir stick dispenser, bulk stir sticks, fits up to 1/8" D x 5 1/2" L (0.32 x 14 cm) straw	7 1/8 x 6 x 5 1/8 (18.1 x 15.3 x 13)	1
MW-1	Waxed paper dispenser, midget size	7 3/16 x 6 x 5 1/8 (18.3 x 15.9 x 13)	1



Bag Dispensers

- Dispenser mounts flush into counter
- Durable ABS construction
- Maximum bag size: 8 3/4" W x 11" L



ITEM #	DESCRIPTION	DIMENSIONS (W X H): IN (CM)	CUTOUT DIMENSIONS (W X H): IN (CM)	CASE LOT
MB-1	Bag dispenser, 2 compartments, flush mount	10 5/8 x 7 1/2 (27 x 19)	9 1/16 x 6 9/16 (24.7 x 16.7)	



In-Counter Napkin Dispensers

- Mounts horizontally, vertically or diagonally



ITEM #	DESCRIPTION	OVERALL DIMENSIONS (D X W X H): IN (CM)	FOLDED NAPKIN SIZE: IN (CM)	INTERFOLD NAPKIN SIZE: IN (CM)	CAPACITY	COLOR	CASE LOT
6535-13	Stainless steel limited in-counter saves 10% usage	19 1/2 x 9 1/2 x 7 3/4 (49.5 x 24.1 x 19.6)	5 x 6 1/2 or 5 1/4 x 6 1/2 (12.7 x 16.5 or 13.3 x 16.5)	4 1/4-5 1/4 x 6 1/2 (10.7 x 13.3 x 16.5)	500	Chrome	1
6525-13	Stainless steel in-counter dispenser	17 13/16 x 9 1/2 x 7 3/4 (45.2 x 24.1 x 19.6)	5 x 6 1/2 or 5 1/4 x 6 1/2 (12.7 x 16.5 or 13.3 x 16.5)	—	500	Clear	1
6525-28	Stainless steel in-counter dispenser	17 13/16 x 9 1/2 x 7 3/4 (45.2 x 24.1 x 19.6)	5 x 6 1/2 or 5 1/4 x 6 1/2 (12.7 x 16.5 or 13.3 x 16.5)	—	500	Chrome	1
FMHVN-1*	Black ABS in-counter high-volume dispenser	19 1/2 x 7 1/8 x 8 1/2 (49.5 x 18.1 x 21.6)	5 x 6 1/2 (12.7 x 16.5)	—	500	Black	1

*Only mounts vertically or horizontally





Breath Guards

An artful combination of form, function and food presentation, Vollrath's line of breath guards effectively provide a stylish barrier between the customer and the prepared food in order to prevent potential contamination and maintain a healthy environment for both customers and the foodservice staff.



Traditional Style



Double-Sided Buffet



Single-Sided Buffet With Top Shelf



Single-Sided Buffet**



Cafeteria With Top Shelf



Vertical Cafeteria**

NSF BREATH GUARDS

Add an "N" to the beginning of the item # to indicate a NSF 2-compliant breath guard.

Note: Breath guards are sized to work with Vollrath drop-ins (exception to slim lines; see spec sheet for sizing)



ITEM #	OVERALL LENGTH: IN (MM)
DOUBLE-SIDED BUFFET	
PB89285	34½ (87.6)
PB89286	47 (119.4)
PB89287	60¼ (153)
PB89288	73½ (186.7)
PB89289	86¾ (220.3)
SINGLE-SIDED BUFFET WITH TOP SHELF	
PB89280	34½ (87.6)
PB89281	47 (119.4)
PB89282	60¼ (153)
PB89283	73½ (186.7)
PB89284	86¾ (220.3)
SINGLE-SIDED BUFFET	
PB89270	34½ (87.6)
PB89271	47 (119.4)
PB89272	60¼ (153)
PB89273	73½ (186.7)
PB89274	86¾ (220.3)
CAFETERIA WITH TOP SHELF	
PB89265	34½ (87.6)
PB89266	47 (119.4)
PB89267	60¼ (153)
PB89268	73½ (186.7)
PB89269	86¾ (220.3)
VERTICAL CAFETERIA	
PB89260	34½ (87.6)
PB89261	47 (119.4)
PB89262	60¼ (153)
PB89263	73½ (186.7)
PB89264	86¾ (220.3)

*Custom lengths available – contact your Vollrath sales representative.

SUFFIX	COLOR
99	Anodized aluminum
00	Chrome
10	Brass
20	Black hammer semigloss
30	Black 80% gloss
40	White hammer
50	Copper vein
60	Silver vein
70	Black/white
80	Silver hammertone

Note: All accessories are 120V. Custom sizes and other accessory voltages also available. Contact your Vollrath sales representative for more information.

Colors are all powder coat colors with the exception of "99" (anodized aluminum, stainless steel).

SUFFIX	OPTIONS
66	2-well fluorescent lights
05	2-well incandescent lights
95	2-well heat strips
13	2-well heat strips with lights
67	3-well fluorescent lights
06	3-well incandescent lights
68	3-well heat strips
01	3-well heat strips with lights
92	4-well fluorescent lights
07	4-well incandescent lights
97	4-well heat strips
02	4-well heat strips with lights
93	5-well fluorescent lights
08	5-well incandescent lights
98	5-well heat strips
03	5-well heat strips with lights
94	6-well fluorescent lights
09	6-well incandescent lights
11	6-well heat strips
04	6-well heat strips with lights

EXAMPLE CONFIGURED ITEM NUMBER

The sample item number below is an NSF model 6-well cafeteria with top shelf, in chrome with a heat strip and lights, mounted on a laminate or solid surface countertop.
Example item#: NPB892690004



NSF + Style (1st 2 letters of item number) | Function & Length | Color | Accessory



Contemporary Style



Double-Sided Buffet



Single-Sided Buffet With Top Shelf



Single-Sided Buffet



Cafeteria With Top Shelf

NSF BREATH GUARDS

Add an "N" to the beginning of the item # to indicate a NSF 2-compliant breath guard.

Note: Breath guards are sized to work with Vollrath drop-ins (exception to slim lines; see spec sheet for sizing).



ITEM # OVERALL LENGTH: IN (MM)

DOUBLE-SIDED BUFFET

CB98663	34½ (87.6)
CB98637	47 (119.4)
CB98638	60¼ (153)
CB98639	73½ (186.7)
CB98640	86¾ (220.3)

SINGLE-SIDED BUFFET WITH TOP SHELF

CB98662	34½ (87.6)
CB98651	47 (119.4)
CB98652	60¼ (153)
CB98653	73½ (186.7)
CB98654	86¾ (220.3)

SINGLE-SIDED BUFFET

CB98661	34½ (87.6)
CB98633	47 (119.4)
CB98634	60¼ (153)
CB98635	73½ (186.7)
CB98636	86¾ (220.3)

CAFETERIA WITH TOP SHELF

CB98660	34½ (87.6)
CB98650	47 (119.4)
CB98626	60¼ (153)
CB98627	73½ (186.7)
CB98628	86¾ (220.3)

*Custom lengths available – contact your Vollrath sales representative.

SUFFIX COLOR

99		Brushed stainless steel
10		Brass
30		Black 80% gloss

Note: All accessories are 120V. Custom sizes and other accessory voltages also available. Contact your Vollrath sales representative for more information.

Colors are all powder coat colors with the exception of "99" (anodized aluminum, stainless steel).

SUFFIX OPTIONS

25	2-well fluorescent lights
52	2-well heat strip
57	2-well heat strip with lights
45	3-well fluorescent lights
53	3-well heat strip
58	3-well heat strip with lights
14	4-well fluorescent lights
54	4-well heat strip
59	4-well heat strip with lights
46	5-well fluorescent lights
55	5-well heat strip
90	5-well heat strip with lights
51	6-well fluorescent lights
56	6-well heat strip
91	6-well heat strip with lights

EXAMPLE CONFIGURED ITEM NUMBER

The sample item number below is an NSF model 6-well cafeteria with top shelf, in brushed stainless steel with a heat strip and lights, mounted on a laminate or solid surface countertop.

Example item#: NCB986289991



NSF + Style Function & Length Color Accessory
(1st 2 letters of item number)



Velocity Adjustable Style

MULTIPLE PRESET POSITIONS

These accommodate NSF, full-serve, self-serve and cleaning position and ensure consistent spacing across multiple units

VELOCITY ADJUSTABLE BREATH GUARD

Prevents contamination, creates an elegant, streamlined appearance and is impressively easy to use

ADDED STABILITY

Welded mitered joints increase structural integrity

HEAVY-DUTY TUBING

11-gauge stainless steel tubing enables 96" span without the need for a counter-mounted center post

SEVERAL STYLES

Available in single-sided buffet, double-sided buffet or cafeteria styles

SHIPPING OPTIONS

Ships knocked down (standard) or assembled (available)



TEMPERED GLASS PANELS
3/8" tempered (standard),
1/2" (available)

VISUAL NSF POSITION INDICATION

Shows when breath guard is in NSF position and eliminates the need for measuring

NO PLASTIC

Stainless steel construction ensures no plastic parts to break and a consistent aesthetic of all components

MOUNTING CHOICES

Above-counter flange mount (standard) and below-counter mounting (available)



EASY ADJUSTMENT
Simple push-button mechanism enables single-person adjustment

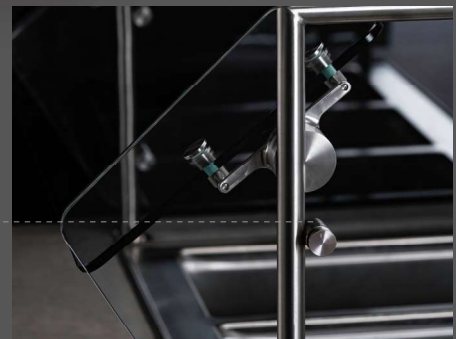



Double-Sided Buffet



Single-Sided Buffet



Cafeteria Buffet

ITEM #	PANS OR WELLS	OVERALL LENGTH: IN (MM)
DOUBLE-SIDED BUFFET		
SS-6BG-022S	2	31 (78.7)
SS-6BG-032S	3	45 (114.3)
SS-6BG-042S	4	59 (149.9)
SS-6BG-052S	5	73 (185.4)
SS-6BG-062S	6	87 (221.0)
FC-6BG-022S	2	34½ (87.6)
FC-6BG-032S	3	47 (119.4)
FC-6BG-042S	4	60¼ (153.0)
FC-6BG-052S	5	73½ (186.7)
FC-6BG-062S	6	86¾ (220.3)
SINGLE-SIDED BUFFET		
SS-6BG-021S	2	31 (78.7)
SS-6BG-031S	3	45 (114.3)
SS-6BG-041S	4	59 (149.9)
SS-6BG-051S	5	73 (185.4)
SS-6BG-061S	6	87 (221.0)
FC-6BG-021S	2	34½ (87.6)
FC-6BG-031S	3	47 (119.4)
FC-6BG-041S	4	60¼ (153.0)
FC-6BG-051S	5	73½ (186.7)
FC-6BG-061S	6	86¾ (220.3)
CAFETERIA		
SS-6BG-021C	2	31 (78.7)
SS-6BG-031C	3	45 (114.3)
SS-6BG-041C	4	59 (149.9)
SS-6BG-051C	5	73 (185.4)
SS-6BG-061C	6	87 (221.0)
FC-6BG-021C	2	34½ (87.6)
FC-6BG-031C	3	47 (119.4)
FC-6BG-041C	4	60¼ (153.0)
FC-6BG-051C	5	73½ (186.7)
FC-6BG-061C	6	86¾ (220.3)

SUFFIX	OPTIONS
HS	Heat strip
LED	LED strip
HSL	Heat strip with LED lighting

*Custom lengths available – contact your Vollrath sales representative.

EXAMPLE CONFIGURED ITEM NUMBER

The sample item number below is an FC (product type), 6BG (6-series breath guard), 02 (well size), 1S (function), HS (accessory).
Example item#: FC-6BG-021S-HS

1 FC-	2 6BG-	3 02	4 1S-	5 HS
Product Type	6-Series Breath Guard	Well Size	Function	Accessory



Light and Heat Strips, Heated Shelves

Vollrath's heat strips are designed to maintain ideal serving temperatures for all your hot food items by providing a consistent, even blanket of heat. Our heated shelves boast a variety of valuable features, including multiple temperature settings, powerful heating, sleek designs and more, that promise to keep all your food items perfectly hot, steamy and fresh.



Low-Profile Heat Strips

- Low profile contributes to a clean aesthetic
- Visibility is improved due to the slim design
- Aluminum heater housing provides lightweight durability
- Bright annealed stainless steel heat reflector enhances heat dispersion and increases the heating zone
- Sheathed element is dependable and lasts longer
- Unique element enhances even and effective warming
- Stainless steel brackets with adjustable screws contribute proper spacing and simple replacement
- Infinite or toggle remote controls allow placement flexibility
- A variety of finishes promote design options



Infinite Control



Toggle Control



FOLLOW THESE STEPS TO BUILD ITEM NUMBER

Note: Heat and light strips cannot be canceled or returned

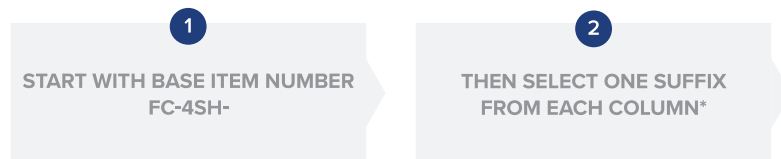

EXAMPLE CONFIGURED ITEM NUMBER

The sample item number below is an 24" length, 120V in natural aluminum finish with an infinite remote control.
Example item#: FC-4SH-24-120-NA-IN



LENGTH: IN	VOLTS	FINISH**	REMOTE CONTROL
18		NA - Natural aluminum	
24		CH - Chrome	
30			
36		BR - Brass	
42			
48	120	BL - Black	IN - Infinite
54	208	WH - White hammer	SW - Toggle switch
60			
66		SI - Silver vein	
72			
84		CO - Copper vein	

**All but natural aluminum finishes are powder coated.



Cayenne® Light Strips

CAYENNE® LIGHT STRIPS ILLUMINATE FOOD SERVING DISPLAY AREAS OR FOOD PREPARATION AREAS

- Structurally engineered aluminum housing offers maximum strength with minimal weight
- Standard polished stainless steel light reflector directs maximum light to the display area
- 120V, single-phase



40-WATT STANDARD BULBS

LENGTH: IN (CM)	MODEL # 	TOTAL NO. BULBS	AMP DRAW
18 (47.7)	7286000	2	0.7
24 (60.9)	7286100	2	0.7
30 (76.2)	7286200	2	0.7
36 (91.4)	7286300	4	1.4
42 (106.6)	7286400	4	1.4
48 (121.9)	7286500	4	1.4
54 (137.1)	7286600	6	2
60 (152.4)	7286700	6	2
66 (167.6)	7286800	6	2
72 (182.8)	7286900	6	2

60-WATT STANDARD BULBS

LENGTH: IN (CM)	MODEL # 	TOTAL NO. BULBS	AMP DRAW
18 (47.7)	7286002	2	1
24 (60.9)	7286102	2	1
30 (76.2)	7286202	2	1
36 (91.4)	7286302	4	2
42 (106.6)	7286402	4	2
48 (121.9)	7286502	4	2
54 (137.1)	7286602	6	3
60 (152.4)	7286702	6	3
66 (167.6)	7286802	6	3
72 (182.8)	7286902	6	3

Note: All light strips are custom ordered and therefore cannot be canceled or returned per Vollrath terms and conditions





Cayenne® Hard-Wired Heat Strips



FOLLOW THESE STEPS TO BUILD ITEM NUMBER

Note: Heat and light strips cannot be canceled or returned

1

CHOOSE WATTAGE AND LENGTH FOR BASE NUMBER

LENGTH: IN	CALROD WATTAGE SINGLE	DUAL	BASE NUMBER
MEDIUM WATTAGE – HARD-WIRED			
18	415	830	72702
24	550	1100	72705
30	690	1380	72708
36	825	1650	72711
42	965	1930	72714
48	1100	2200	72717
54	1240	2480	72720
60	1380	2760	72723
66	1515	3030	72726
72	1660	3320	72729
84	1930	3860	72732
HIGH WATTAGE – HARD-WIRED			
18	540	1080	72703
24	720	1440	72706
30	900	1800	72709
36	1080	2160	72712
42	1260	2520	72715
48	1435	2870	72718
54	1615	3230	72721
60	1800	3600	72724
66	1980	3960	72727
72	2160	4320	72730
84	2520	5040	72733

Note: 66" to 84" length units are not available in 120V

2

ADD VOLTAGE TO BASE NUMBER

SIZE	120V SUFFIX	208V SUFFIX	240V SUFFIX
WITHOUT LIGHTS			
Single	01	02	03
Dual	21	22	23
WITH LIGHTS			
Single	11	12	13
Dual	31	32	33

See Page 46 for lighted section amp draw and bulb quantity supplied

3

ADD CONTROL TO BASE NUMBER

ITEM	END MOUNT WIRING BOX SUFFIX**	FRONT MOUNT WIRING BOX SUFFIX
Onboard toggle***	—	9
Remote toggle	6	61
Remote infinite switch	7	71
No control (oem applications)	5	51

*Controls cannot be retrofitted
**Adds 2" to overall length of unit – refer to spec sheet
***On-board toggle not available on high-wattage heat strips – refer to spec sheet

- Heat end to end – minimizing the 6" to 9" cold zones found in other models
- 33% larger "food safe" zone allows you to hold more food at safe, consistent temps



CAYENNE® HEAT STRIP MODEL

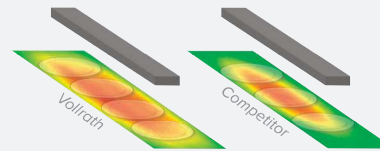

Thermal images of heat profile radiating from aluminum surface after three-hour use – 36" heat strip units from 11" high

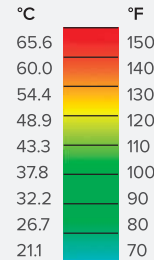

EXAMPLE CONFIGURED ITEM NUMBER

The sample item number shown here is a 60" medium wattage, hard-wired, 208V dual with lights and remote toggle.
Example item#: 727233261

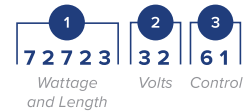



Light and Heat Strips

- Master on/off switch
- Stainless steel mounting assembly
- Incandescent/infrared accepts standard base incandescent bulbs or heat lamps up to 250W; cone-shaped reflector shields concentrate heat over well
- Clear plastic tube shield for fluorescent lights
- Heat strips cannot be specified for double-shelf cafeteria breath guard
- Access® adjustable breath guards have 9" to 15" (22.9 to 38.1 cm) serving opening height adjustment



DESCRIPTION	ITEM # ENTRÉE UNIT	ITEM # L: 46 IN (117 CM)	ITEM # L: 60 IN (152 CM)	ITEM # L: 74 IN (188 CM)	ITEM # L: 88 IN (224 CM)
Incandescent/infrared*	36440	36431	36432	36433	98625
Fluorescent*		36421	36422	36423	98622
Heat strip		36401	36402	36403	98623
Heat strip with lights*		36411	36412	36413	98624

*Bulbs and lamps not supplied – order separately.
White 250W bulb – item 72242. Red 500W bulb – item 72241.

Teflon® Coated Shatterproof Light Bulbs

- Replacement bulbs – item 23236, case lot 4



UNIT LENGTH: IN	NO. OF 40-WATT BULBS	TOTAL AMP (120V)
18-30	2	.7
36-48	4	1.4
54-72	6	2.1
84	8	2.8

Kool-Touch® Black Trim

- Prevents burns from contact with side surface
- Enhances the visual appearance of the heat strips or light strips
- Field retrofittable



TRIM LENGTH: IN (CM)	ITEM #	CASE LOT
18 (47.7)	1789718	2
24 (60.9)	1789724	2
30 (76.2)	1789730	2
36 (91.4)	1789736	2
42 (106.6)	1789742	2
48 (121.9)	1789748	2
54 (137.1)	1789754	2
60 (152.4)	1789760	2
66 (167.6)	1789766	2
72 (182.8)	1789772	2

For lengths over 72" (182.8 cm), order trim in two pieces that equal the desired length. Some field trimming required.

Hard-Wired Mounting Options

Noncombustible surfaces may use 1" clearance.
Combustible surfaces require 2" clearance.



BRACKET STYLE	IN (CM)	ITEM #	CASE LOT
Top surface mount (2 per set)	1 (2.54)	44545	2
	2 (5.08)	44546	2
Center mount	1 (2.54)	44140	1
	2 (5.08)	44145	1

Double the recommended number of brackets for dual units.
Center mount brackets are suggested for units over 72" (182.8 cm) in length. They may be used alone or in combination with top surface mount brackets.

RECOMMENDED NUMBER OF CENTER MOUNT BRACKETS

UNIT LENGTH: IN (CM)	# OF BRACKETS
18 (45.7)	2
> 18 (45.7)	3
> 42 (106.7)	4
> 60 (152.4)	5
> 84 (213.4)	6



Flush-Mount Heated Shelf Drop-Ins

- Two separate warming zones can be used individually or together for maximum energy efficiency during low and peak serving times
- Warming zones are easily identified by stamped marks
- Nine heat settings
- Digital thermostatic heat control keeps food warm without affecting its quality of the food
- Zero-clearance design enables the drop-in to be installed into most countertop materials



Ideal for grab-and-go hot food self-serve food operations and for buffets. Sized to uniformly align with other Vollrath drop-ins for a clean visual presentation.



Natural Stainless Steel



Black Aluminum Hardcoat

RECESSED ITEM #	FLUSH-MOUNT ITEM #	OVERALL LENGTH: IN (CM)	MAX WEIGHT CAPACITY: LB (KG)	VOLTAGE: AC	WATTS	AMPS	HZ	PLUG
NATURAL STAINLESS STEEL FINISH								
FC-4HS-24120-SSR	FC-4HS-24120-SSF	24 (61)	50 (22.7)	120	304	2.5	60	NEMA 5-15P
FC-4HS-30120-SSR	FC-4HS-30120-SSF	30 (76.2)	78 (35.4)		386	3.2		
FC-4HS-36120-SSR	FC-4HS-36120-SSF	36 (91.4)	106 (48)		468	3.9		
FC-4HS-42120-SSR	FC-4HS-42120-SSF	42 (106.7)	134 (60.8)		549	4.6		
FC-4HS-48120-SSR	FC-4HS-48120-SSF	48 (121.9)	163 (73.9)		631	5.3		
FC-4HS-54120-SSR	FC-4HS-54120-SSF	54 (137.2)	191 (86.6)		712	5.9		
FC-4HS-60120-SSR	FC-4HS-60120-SSF	60 (152.4)	219 (99.3)		794	6.6		
FC-4HS-66120-SSR	FC-4HS-66120-SSF	66 (167.6)	247 (112)		876	7.3		
FC-4HS-72120-SSR	FC-4HS-72120-SSF	72 (182.9)	275 (124.7)		957	8.0		
BLACK ALUMINUM HARDCOAT FINISH								
FC-4HS-24120-BKR	FC-4HS-24120-BKF	24 (61)	50 (22.7)	120	304	2.5	60	NEMA 5-15P
FC-4HS-30120-BKR	FC-4HS-30120-BKF	30 (76.2)	78 (35.4)		386	3.2		
FC-4HS-36120-BKR	FC-4HS-36120-BKF	36 (91.4)	106 (48)		468	3.9		
FC-4HS-42120-BKR	FC-4HS-42120-BKF	42 (106.7)	134 (60.8)		549	4.6		
FC-4HS-48120-BKR	FC-4HS-48120-BKF	48 (121.9)	163 (73.9)		631	5.3		
FC-4HS-54120-BKR	FC-4HS-54120-BKF	54 (137.2)	191 (86.6)		712	5.9		
FC-4HS-60120-BKR	FC-4HS-60120-BKF	60 (152.4)	219 (99.3)		794	6.6		
FC-4HS-66120-BKR	FC-4HS-66120-BKF	66 (167.6)	247 (112)		876	7.3		
FC-4HS-72120-BKR	FC-4HS-72120-BKF	72 (182.9)	275 (124.7)		957	8.0		



Drop-In Display Cases

- Attractively designed base allows display to be used either as a drop-in or as a freestanding countertop unit; use two or more units to create excellent heated/refrigerated merchandising display lineups
- Inside lighting strips located both at the top of the cabinet and underneath the upper shelf create optimum food display throughout cabinet
- Dual fans circulate air throughout unit to ensure even temperature control
- Double-glazed front glass gives added strength and insulation
- Lift-and-remove rear sliding doors for easy display changes and end-of-day cleaning
- Digitally controlled thermostat for precise and consistent settings
- Note: These items must be shipped by truck



ITEM #	MODEL #	DESCRIPTION	OVERALL DIMENSIONS (L X W X H): IN (CM)	HP	VOLTAGE: AC	AMPS	PLUG
REFRIGERATED DISPLAY CABINETS – TEMPERATURE RANGE 36° TO 46°F							
40842	RDE7136	36" refrigerated display cabinet	21 x 36 x 32½ (53.3 x 91.4 x 82.6)	¼	120	3.4	5-15P
40843	RDE7148	48" refrigerated display cabinet	21 x 48 x 32½ (53.3 x 121.9 x 82.6)	¼	120	4.2	5-15P
40844	RDE7160	60" refrigerated display cabinet	21 x 60 x 32½ (53.3 x 152.4 x 82.6)	¼	120	4.4	5-15P
HEATED DISPLAY CABINETS – TEMPERATURE RANGE 104° TO 158°F				WATTS	VOLTAGE: AC	AMPS	PLUG
40845	HDE7136	36" heated display cabinet	21 x 36 x 32½ (53.3 x 91.4 x 82.6)	670	120	5.6	5-15P
40846	HDE7148	48" heated display cabinet	21 x 48 x 32½ (53.3 x 121.9 x 82.6)	710	120	5.9	5-15P
40847	HDE7160	60" heated display cabinet	21 x 60 x 32½ (53.3 x 152.4 x 82.6)	750	120	6.3	5-15P



NEW

SerVue™ Touchless Refrigerated Slide-In

High-capacity food canisters keep ingredients separate, helping maintain the integrity of the food and reducing risks of cross-contamination, which makes it easier to accommodate dietary restrictions

Eight canisters allow you to easily interchange or replenish a variety of ingredients

Adjustable portion controls put you in charge of serving sizes and allow for easy tracking of number of servings, product inventory, and usage

Touchless proximity sensors dispense predetermined portions, eliminating need for serving utensils and increasing speed of service

Enclosed refrigerated design maintains safe temperatures and protects ingredients from contamination, keeping food fresher longer





Maximize space
 Fits into same space as a traditional 4-well drop-in
Shown installed in a 4-Series base

ITEM #	DIMENSIONS (W X H X D): IN (CM)	APPLIANCE AREA (D X W): IN (CM)	BASE UNIT VOLTAGE: AC	HZ	AMPS	WEIGHT: LBS (KG)	PLUG
FC-4TD-28120-C	51.5 x 65.6 x 21.4 (130.8 x 166.5 x 54.3)	18 1/4 x 35 (46.4 x 88.9)	120	60	5.3	425 (192.8)	NEMA 5-15P

Approved Food



Efficient serving

Two sets of sensors allow for simultaneous dispensing to keep the line moving



No teardown

Unlike a traditional open-air food bar, SerVue doesn't have to be taken down at the end of service. Food remains at a safe temperature until the next rush







Serving Systems

Creating a custom serving system design is a time-consuming, collaborative process. Fortunately, Vollrath has the experience and expertise to guide you through every step of the process.



6-Series
Front-of-House



6-Series
Back-of-House



4-Series
Front-of-House



4-Series
Back-of-House



2-Series
Front-of-House



2-Series
Back-of-House



Introduction to Serving Systems



Serving systems are perfect for stadiums, airports, hospitals, K-12 schools, universities, and other locations where you need to serve customers quickly and conveniently.

While we offer turnkey solutions, our serving systems are completely customizable to meet your use and branding requirements. You can choose everything from size and shape to countertop materials and colors. Each piece of equipment comes pre-plumbed and prewired, so it will run off a single electrical connection.

The pages that follow show just some of your options. When you're ready to start planning your customized solution, give us a call. Our team collaborates continually across all of our manufacturing facilities to ensure you get exactly what you want.

Common Serving System Locations



Education



Health Care



Grocery & Convenience Stores



Business & Industry



Travel & Leisure



Restaurants & Bars



Cart

Completely self-contained, carts are mobile, modular pieces designed to work alone or together. They can be moved as needed and provide excellent flexibility. Carts are perfect for expanding your foodservice offering or adding auxiliary service. *WHERE TO USE: K-12, colleges, stadiums, arenas, theme parks, hospitals, assisted living, hospitality and airports.*



Kiosk

Designed for a fixed setting, kiosks are fully enclosed structures or a system of carts/cabinets with larger electrical systems than carts. Kiosks can be secondary foodservice solutions or used on their own. *WHERE TO USE: Malls, airports, theme parks, colleges, hospitals, stadiums and arenas.*

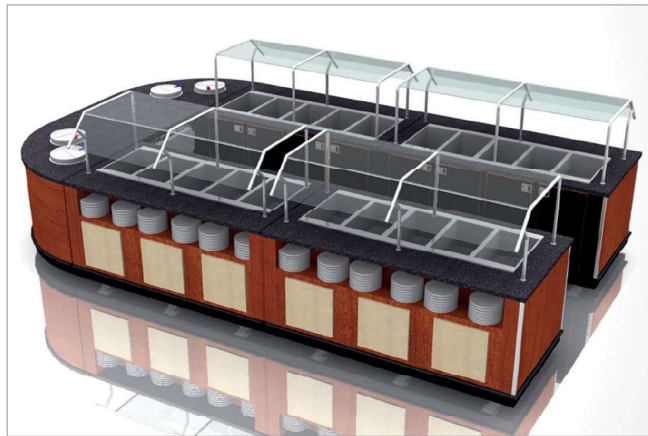

Serving Line

Designed for either a long, single line or a more modular design, serving lines are an option for buffet or full service. They typically focus on a particular type of food such as a salad bar, hot foods or cold foods. *WHERE TO USE: K-12, colleges, hospitals, government, military, hotels, assisted living, business and industry, and supermarkets.*



Retail Merchandising Unit

Much larger than kiosks, big buildings typically have their own floor and are approximately 15-20 feet long and 8-10 feet deep. They work well for pop-up food service as well as merchandise shops and, while designed to be semi-permanent, can be moved with large equipment. *WHERE TO USE: Malls, nontraditional spaces, stadiums and arenas.*



Front-of-House Series Comparison



6-Series

Fully customizable with extensive material options, 6-Series systems are designed, engineered and manufactured to meet your specific requirements. Traditional custom fabrication available.

PAGES 61-69

CUSTOMIZATION

★★★★★ Custom fabricated

WARRANTY



Two-year parts and labor warranty

COST

\$\$\$

NOTABLE OPTIONS

Custom fabrication of canopies, complete merchandising, including signage and menu boards, integrated plate storage, backlit signage, 3D graphics, facades, single-point electrical connection

DÉCOR OPTIONS



Hundreds of laminates, veneers, vinyl graphics, custom-matched automotive-grade paint, or 3D facade graphics

BASE CONSTRUCTION OPTIONS



Stainless steel



Millwork

COUNTERTOP MATERIAL OPTIONS



Man-made quartz



Acrylic solid surface



Stainless steel



Laminate

BREATH GUARDS

Vollrath-branded and all other major breath guard brands, including all lighting and heat options

All units are made to order and cannot be returned or canceled



4-Series

These modular designs offer size, shape and material options at an affordable price point.

PAGES 70-77

★★★★ Standard items with modifications



One-year parts and labor warranty (two-year optional)

\$\$

Modifications include storage, countertops with different drop-in combinations, fill faucets



Vinyl graphics, hundreds of laminate options, or stainless steel



Stainless steel



Stainless steel

Available with countertop-mounted breath guards; LED, fluorescent or incandescent lighting; and heat strips



2-Series

Designed for the budget-conscious organization, 2-Series systems offer a choice of two sizes and seven colors.

PAGES 80-86

★★ Standard items



One-year parts and labor warranty

\$

Storage, lighting, breath guards



Five standard colors



Vinyl-clad carbon steel



Stainless steel

Standard countertop-mounted buffet and cafeteria-style breath guards only

All units are made to order and cannot be returned or canceled

How To Shop



6-Series

With endless possibilities and top-quality construction, 6-Series systems are designed, engineered and manufactured to meet your specific requirements.

4-Series

Our 4-Series modular designs offer many combinations of materials, equipment and accessories without the longer lead time of a fully customizable option — a great option for businesses looking for a unique touch at a more affordable price point.



FRONT-OF-HOUSE
PAGES 61-69



FRONT-OF-HOUSE
PAGES 70-77



BACK-OF-HOUSE
PAGES 87-88



BACK-OF-HOUSE
PAGES 89-92

2-Series

The 2-Series system is designed for the budget-conscious organization. What is lacking in customization is made up for in functionality — available in multiple configurations.



FRONT-OF-HOUSE
PAGES 80-86



BACK-OF-HOUSE
PAGES 93-96



6-Series Front-of-House

Fully customizable with extensive material options, 6-Series systems are designed, engineered and manufactured to meet your specific requirements.



6-Series Front-of-House

Construction Materials

We'll help you determine the best construction materials for your budget, function and durability needs.

300 Stainless Steel (SS)

- 300 series, 18-gauge stainless steel



CONSTRUCTION

Unibody or heavy-duty framed construction

AESTHETICS

- Brushed stainless steel finish
- Standard and premium laminates
- Custom vinyl graphic wraps

COMMON CONFIGURATIONS

- Squared-corner cabinetry and slight curves
- Maximum length of a single unit without custom seaming is 116"
- Standard hot and cold food stations, utility stations, cashier stations
- Modular construction – can appear seamless or be individual stations

LOCATION – INDOOR OR OUTDOOR USE BASED ON DÉCOR/FINISH SELECTION

COST – \$\$\$

APPLICATION

An industry favorite for its stainless steel unibody durability and ability to be formed while maintaining a clean appearance. Whether in the front or back of the house, or in the back of the house, a stainless steel finish can be standardized across several pieces for a uniform appearance.



6-Series Front-of-House Décor Materials

With a wide range of material options, you get the flexibility you need for a fully customized look.



LAMINATES

Choose from a variety of manufacturers and colors
Available as solid colors or with textures



VINYL GRAPHICS

UV-protected clear adhesive over laminate
Great way to extend a brand and mix with other décor features

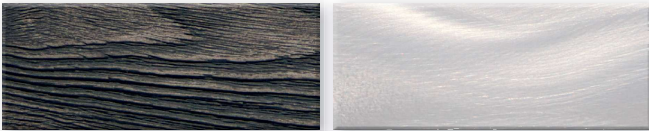

UNIQUE DÉCOR

Faux textured décor, custom metal laminates, stained-wood décor elements, or mix and match for a unique look
Endless design choices

PRICE LEVEL	INDOOR/ OUTDOOR	SCRATCH RESISTANCE	STAIN RESISTANCE	RENEWABLE & REPAIRABLE	NUMBER OF CHOICES	FLEXIBILITY IN DESIGN APPLICATIONS
LAMINATES						
\$\$\$	INDOOR	★★★	★★★	★	★★	★★
VINYL GRAPHICS						
\$\$	BOTH	★★★	★★★★	★	★★★	★★★
UNIQUE DÉCOR						
\$\$\$	BOTH	★★★★	★★★	★★★	★★	★★★



Discover Wood Trends

With an infinite number of combinations of décor elements from standard laminates to faux textured finishes and real wood, Vollrath can design and build a unit that is as unique as your foodservice operation. Explore vollrathfoodservice.com to see just a small group of examples that highlight our décor options and how they can work together to create a new destination for your customers.





6-Series Front-of-House Countertops

Get the look you want with a wide range of countertop options designed to fit your durability requirements and budget.

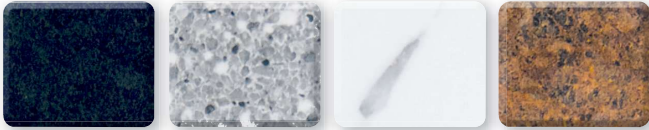

LAMINATES

Choose from a variety of manufacturers and colors
Laminate is applied to a 1½" substrate to create a simple counter



STAINLESS STEEL

Stainless steel countertops are our most durable option and are sure to last
Available in a variety of gauges with several edge detail options



ACRYLIC SOLID SURFACE

Choose from a variety of manufacturers and colors
½" thick acrylic is applied to a 1" substrate with a variety of edge detail options

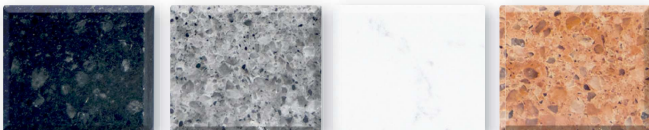

MAN-MADE QUARTZ

Choose from hundreds of colors from a variety of manufacturers like Formica, Wilsonart, Cambria and Caesarstone
Available in 2 cm and 3 cm thicknesses with a variety of edge detail options
Special considerations must be made based on equipment choices

PRICE LEVEL	SCRATCH RESISTANCE	STAIN RESISTANCE	HEAT RESISTANCE	SCORCH RESISTANCE	RENEWABLE & REPAIRABLE	SEAMLESS APPEARANCE	NONPOROUS
LAMINATES							
\$	★	★	★	★	★	★	★
	★	★	★			★	★
		★					
STAINLESS STEEL							
\$	★	★	★	★	★	★	★
\$	★	★	★	★	★		★
	★	★	★	★			★
		★	★				★
ACRYLIC SOLID SURFACE							
\$	★	★	★	★	★	★	★
\$	★	★	★		★	★	★
\$	★	★	★		★	★	★
					★		★
MAN-MADE QUARTZ							
\$	★	★	★	★	★	★	★
\$	★	★	★	★		★	★
\$	★	★	★	★			★
\$	★	★	★	★			★



Endless Possibilities & Customization

The Vollrath industrial design team and project coordinators can help you choose the right countertop material to best fit your needs. We will help you through the tough decisions to make sure your finished project exceeds your expectations.

EDGES // Add modern or traditional lines to your serving unit with your countertop choice



caesarstone



C A M B R I A

CORIAN
SOLID SURFACES

MANUFACTURERS // We partner with the best in the business to ensure quality and customization



LG HI-MACS[®]
Acrylic Solid Surface



SILESTONE
by COSENTINO



Wilsonart

ZODIAQ
QUARTZ SURFACES



6-Series Front-of-House Equipment

Whether it's your equipment or ours, we can install it – from beer kegs and display cases to popcorn machines and soup warmers. And because we're a single-source manufacturer, we can help you find the equipment you can trust. Below is just some of the equipment we design and manufacture.



INDUCTION DROP-INS
PAGES 10-17

Induction drop-ins heat food quickly and keep it hot without water. There's no filling, no refilling, and no scaling. They start up immediately and allow you to set a precise temperature or choose a power level. No water, no steam, no drain, no hassle.



HOT DROP-INS
PAGES 10-24

Available in a wide range of container sizes and shapes, our hot drop-ins maintain the freshness and quality of the food.



COLD DROP-INS
PAGES 25-28

Available in a wide range of container sizes and shapes, our cold drop-ins maintain the freshness and quality of the food.



COMBINATION HOT/COLD DROP-INS
PAGE 29

Available in a wide range of container sizes and shapes, our hot/cold drop-in wells can change from a cold salad bar to a hot buffet – or a combination – with the flip of a switch.



INDUCTION RANGES
PAGES 30-31

With options for light use/warming as well as heavy-duty use, our drop-in induction ranges offer precise dial control. Their streamlined appearance can enhance your serving equipment's look while adding convenient functionality.



FLEXVENT™
PAGES 32-33

Available in a wide range of container sizes and shapes, our cold drop-ins maintain the freshness and quality of the food.



SINKS
PAGES 34-37

Constructed of 20- or 22-gauge stainless steel, our sinks are built to withstand the tough demands of your kitchen.



DISPENSERS & ORGANIZERS
PAGES 38-41

Maximize limited space and keep operations tidy at busy self-serve stations with the LidSaver® 3 dispenser and a full line of straw, condiment, tissue, napkin, and a variety of other dispensers.



DISPLAY CASES
PAGE 51

From self-service to drop-in, well-merchandised food sells better. Give your foods the attention they deserve while keeping them at the right temperature with our display cases and cabinets. They feature digitally controlled thermostats and dual fans to ensure even temperature control. Available in both self-serve and operator-serve styles.



SERVUE™
PAGES 52-53

This self-contained refrigerated cabinet replaces open salad bars in the space of a 4-well drop-in. Ingredients are stored behind lit insulated glass doors, in covered canisters to maintain food-safe temperatures and reduce contaminants and waste. The touchless, self-serve design automatically dispenses predetermined portions, while remaining food is stored in configurable covered canisters.



6-Series Breath Guards

1 CHOOSE A STYLE



TRADITIONAL
PAGE 42



CONTEMPORARY
PAGE 43

2 DETERMINE YOUR FUNCTION & LENGTH



DOUBLE-SIDED
BUFFET



SINGLE-SIDED BUFFET
WITH TOP SHELF



SINGLE-SIDED
BUFFET



CAFETERIA WITH
TOP SHELF

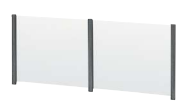

VERTICAL
CAFETERIA

3 DEFINE YOUR COLOR PALETTE



ANODIZED
ALUMINUM



CHROME



BRASS



BLACK
HAMMER



BLACK
80% GLOSS



WHITE
HAMMER



COPPER
VEIN



SILVER
VEIN



BLACK/
WHITE



SILVER
HAMMERTONE

4 SELECT YOUR ACCESSORIES



LIGHTING OPTIONS
LED, Fluorescent, Incandescent
PAGE 47



HEAT STRIPS
PAGES 46, 48-49



HEAT STRIPS WITH LIGHTS
PAGE 49

DOWNDRAFT VENT SYSTEM WITH INDUCTION & FIRE SUPPRESSION

PAGES 78-79





Serving Systems in Action

BELLIN MEMORIAL HOSPITAL

Bellin can now offer fresh, made-to-order food, all day long. It's better quality than ever before, and can be customized to guests' dietary needs and preferences. The interchangeable equipment allows them to switch up their menu selection as often as they like, so there's always something new and exciting to offer their guests.



AUBURN UNIVERSITY

The goal for the renovated dining hall was a setup that allowed moving students through quickly and efficiently while offering variety and custom food choices. Challenges they faced included congestion where serving lines converged and working around a structural column that bottlenecked foot traffic.



LAKELAND UNIVERSITY

Our assignment was to serve Lakeland University students with unparalleled efficiency while showcasing a whole line of fresh food options. Vollrath came through to deliver an experience that's fast, effective and flexible enough to satisfy the lifestyle of today's student body.





Full-Service Process:

WE DESIGN. WE ENGINEER. WE MANUFACTURE.



L
S

To learn more about the Bellin Memorial Hospital case study, scan here.

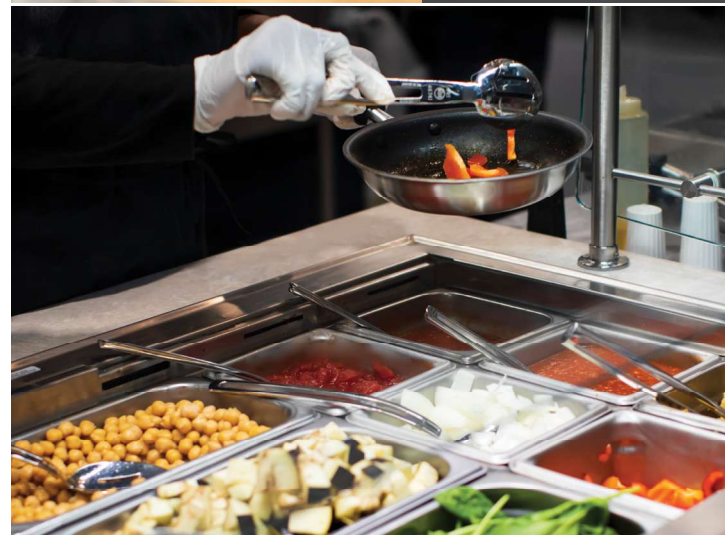

To learn more about the Auburn University case study, scan here.



To learn more about the Lakeland University case study, scan here.





4-Series Front-of-House

4-Series modular designs have several sizes, shapes and material options but are not fully customizable. Signature Server has the components to fit your business's needs.



4-Series Front-of-House Base Configuration

Rectangular Bases With Integrated Equipment (Stainless Tops Only)



Hot Food Bases With
Touch-Temp® Panel



Bain-Marie Hot Stations



NSF 7 Cold Stations



Cold Food Stations



Hot/Cold Food Stations

ITEM	DESCRIPTION	DIMENSIONS (L X W): IN (CM)	NSF LISTED	UL LISTED	ITEM # H: 34" (86 CM)	ITEM # H: 30" (76 CM)	ITEM # H: 27" (69 CM)
Hot food base with Touch-Temp panel	3-well	46 x 28 (117 x 71)	NSF	UL	37030	36130	36230
Hot food base with Touch-Temp panel	4-well	60 x 28 (152 x 71)	NSF	UL	37040	36140	36240
Hot food base with Touch-Temp panel	5-well	74 x 28 (188 x 71)	NSF	UL	37050	36150	36250
Hot food base with Touch-Temp panel	6-well	88 x 28 (224 x 71)	NSF	UL	98888	—	—
Bain-marie hot station	3-well	46 x 28 (117 x 71)	—	UL	37047	36447	36347
Bain-marie hot station	4-well	60 x 28 (152 x 71)	—	UL	37057	36457	36357
Bain-marie hot station	5-well	74 x 28 (188 x 71)	—	UL	37067	36468	36367
Bain-marie hot station	6-well	88 x 28 (224 x 71)	—	UL	37077	3647700	36377
Cold station	NSF 7 refrigerated	46 x 28 (117 x 71)	NSF	UL	37046	36146	—
Cold station	NSF 7 refrigerated	60 x 28 (152 x 71)	NSF	UL	37066	36166	—
Cold station	NSF 7 refrigerated	74 x 28 (188 x 71)	NSF	UL	37076	36176	—
Cold station	NSF 7 refrigerated	88 x 28 (224 x 71)	NSF	UL	98710	—	—
Cold station	Refrigerated	46 x 28 (117 x 71)	—	UL	37045	36145	36245
Cold station	Refrigerated	60 x 28 (152 x 71)	—	UL	37065	36165	36265
Cold station	Refrigerated	74 x 28 (188 x 71)	—	UL	37075	36175	36275
Cold station	Refrigerated	88 x 28 (224 x 71)	—	UL	98708	—	—
Cold station	Nonrefrigerated	46 x 28 (117 x 71)	NSF	—	37043	36143	36243
Cold station	Nonrefrigerated	60 x 28 (152 x 71)	NSF	—	37060	36160	36260
Cold station	Nonrefrigerated	74 x 28 (188 x 71)	NSF	—	37070	36170	36270
Cold station	Nonrefrigerated	88 x 28 (224 x 71)	NSF	—	98707	—	—
Hot/cold food station	Refrigerated	74 x 28 (188 x 71)	NSF	UL	37095	36195	36295
Hot/cold food station	Non-refrigerated	74 x 28 (188 x 71)	NSF	UL	37091	36191	36291



Rectangular Bases With Integrated Equipment (Stainless Tops Only), continued



Utility Stations



Beverage Counters



Universal Corner Station



Frost Top Stations



Cashier Station



Tray and Flatware Cart

ITEM	DIMENSIONS (L X W): IN (CM)	NSF LISTED	UL LISTED	ITEM # H: 34" (86 CM)	ITEM # H: 30" (76 CM)	ITEM # H: 27" (69 CM)
Utility station	28 x 28 (71 x 71)	NSF	UL	37020	36120	36220
Utility station	46 x 28 (117 x 71)	NSF	UL	37021	36121	36221
Utility station	60 x 28 (152 x 71)	NSF	UL	37022	36122	36222
Utility station	74 x 28 (188 x 71)	NSF	UL	37023	36123	36223
Utility station	88 x 28 (224 x 71)	NSF	UL	98711	—	—
Beverage counter	46 x 28 (117 x 71)	NSF	—	37025	36125	—
Beverage counter	60 x 28 (152 x 71)	NSF	—	37026	36126	—
Beverage counter	74 x 28 (188 x 71)	NSF	—	37027	36127	—
Universal corner station	28 x 28 (71 x 71)	NSF	UL	37085	36185	36285
Frost top station	46 x 28 (117 x 71)	—	UL	37012	36112	36212
Frost top station	60 x 28 (152 x 71)	—	UL	37013	36113	36213
Frost top station	74 x 28 (188 x 71)	—	UL	37014	36114	36214
Frost top station	88 x 28 (224 x 71)	—	UL	36115	36117	36116
Cashier station	28 x 28 (71 x 71)	NSF	UL	37015	—	—
Tray and flatware cart	38 x 22½ (96.5 x 57.2)	NSF	—	99305	—	—



Rectangular Bases

ITEM #	DESCRIPTION	DIMENSIONS (L X W): IN (CM)	ITEM #	DESCRIPTION	DIMENSIONS (L X W): IN (CM)
97030	3-well hot – base	48 x 32 (122 x 81)	97065	4-pan nonrefrigerated – base	62 x 32 (157 x 81)
97040	4-well hot – base	62 x 32 (157 x 81)	97075	5-pan nonrefrigerated – base	76 x 32 (193 x 81)
97050	5-well hot – base	76 x 32 (193 x 81)	97084	6-pan nonrefrigerated – base	90 x 32 (229 x 81)
97060	6-well hot – base	90 x 32 (229 x 81)	97220	32" utility – base	32 x 32 (81 x 81)
97047	3-well hot bain-marie – base	48 x 32 (122 x 81)	97221	48" utility – base	48 x 32 (122 x 81)
97057	4-well hot bain-marie – base	62 x 32 (157 x 81)	97222	62" utility – base	62 x 32 (157 x 81)
97067	5-well hot bain-marie – base	76 x 32 (193 x 81)	97223	76" utility – base	76 x 32 (193 x 81)
97077	6-well hot bain-marie – base	90 x 32 (229 x 81)	97233	90" utility – base	90 x 32 (229 x 81)
97046	3-pan NSF 7 cold – base	48 x 32 (122 x 81)	97025	48" beverage – base	48 x 32 (122 x 81)
97066	4-pan NSF 7 cold – base	62 x 32 (157 x 81)	97026	62" beverage – base	62 x 32 (157 x 81)
97076	5-pan NSF 7 cold – base	76 x 32 (193 x 81)	97027	76" beverage – base	76 x 32 (193 x 81)
97086	6-pan NSF 7 cold – base	90 x 32 (229 x 81)	97212	48" frost top – base	48 x 32 (122 x 81)
97043	3-pan std ref. – base	48 x 32 (122 x 81)	97013	62" frost top – base	62 x 32 (157 x 81)
97061	4-pan std ref. – base	62 x 32 (157 x 81)	97014	76" frost top – base	76 x 32 (193 x 81)
97070	5-pan std ref. – base	76 x 32 (193 x 81)	97216	90" frost top – base	90 x 32 (229 x 81)
97080	6-pan std ref. – base	90 x 32 (229 x 81)	97085	Corner station	32 x 32 (81 x 81)
97045	3-pan nonrefrigerated – base	48 x 32 (122 x 81)	97215	Cashier station	32 x 32 (81 x 81)



4-Series Front-of-House Décor Color & Texture

COLOR AND TEXTURE OPTIONS

- All 4-Series base units come standard with 18-gauge stainless steel countertops and black laminate bases
- Endless optional-color laminates and vinyl veneer chips are available through local building supply vendors
- Formica, Nevamar, Pionite, and Wilsonart laminate finishes, among others
- Units can be ordered with all stainless steel construction
- Contemporary textured countertop and plate rest available on stainless steel construction



MATTE LAMINATE ITEM #	WOODGRAIN ITEM #	STAINLESS ITEM #	TEXTURED STAINLESS ITEM #	DESCRIPTION
36680	36687	36693	—	Corner station and 46"-48" (177-122 cm) units
36681	36688	36694	—	60"-62" (152-157 cm) units
36682	36689	36695	—	74"-76" (188-193 cm) units
98835	98835	98836	—	88"-90" (224-229 cm) units
36683	36690	36696	—	28"-32" (71-81 cm) utility and entrée cart
36685	36691	36697	—	Cashier station
36686	36692	—	—	Tray and flatware
—	—	—	98616	Crescent textured countertop
—	—	—	98617	Crescent textured plate rest (each)

Choose from one of our four standard graphics packages, or create your own for a custom look.



4-Series Front-of-House Countertops

- Get the look you want with a wide range of countertop options designed to fit your durability requirements and budget
- We will help you through the tough decisions to make sure your finished project exceeds your expectations



STAINLESS STEEL



4-Series Front-of-House Breath Guards

1 CHOOSE A STYLE



TRADITIONAL

PAGE 42



CONTEMPORARY

PAGE 43



VELOCITY

PAGES 44-45

CLASSIC CAFETERIA
(for stainless steel counter only)

PAGE 74

CLASSIC ECONOMY
(for stainless steel counter only)

PAGE 74

ACCESS®
(for stainless steel counter only)

PAGE 74

2 DETERMINE YOUR FUNCTION & LENGTH

DOUBLE-SIDED
BUFFETSINGLE-SIDED BUFFET
WITH TOP SHELFSINGLE-SIDED
BUFFETCAFETERIA WITH
TOP SHELFVERTICAL
CAFETERIA

3 DEFINE YOUR COLOR PALETTE

ANODIZED
ALUMINUM

CHROME



BRASS

BLACK
HAMMERBLACK
80% GLOSSWHITE
HAMMERCOPPER
VEINSILVER
VEINBLACK/
WHITESILVER
HAMMERTONE

4 SELECT YOUR ACCESSORIES



FLOURESCENT LIGHTS

PAGE 74



INCANDESCENT LIGHTS

PAGE 74



HEAT STRIPS

PAGES 46, 48-49



HEAT STRIPS WITH LIGHTS

PAGE 49



Breath Guards for Stainless Steel Counters Only

- Stainless steel construction
- ¼" (0.6 cm) acrylic breath guard panels
- Cafeteria guards have 300 series stainless steel top shelf, and double-shelf model has adjustable front breath guard panels with middle acrylic shelf
- Access® adjustable breath guards have 9" to 15" (22.9 to 38.1 cm) serving opening height adjustment



Single-Shelf Cafeteria



Double-Shelf Cafeteria



Economy Buffet



Access® Buffet

DESCRIPTION	ITEM # L: 28 IN (71 CM)	ITEM # L: 46 IN (117 CM)	ITEM # L: 60 IN (152 CM)	ITEM # L: 74 IN (188 CM)	ITEM # L: 88 IN (224 CM)
CLASSIC CAFETERIA BREATH GUARDS					
Single-shelf cafeteria	37310	37311	37312	37313	9861006
NSF 2 single-shelf cafeteria	N37310	N37311	N37312	N37313	N9861006
Double-shelf cafeteria	37320	37321	37322	37323	9861707
CLASSIC ECONOMY BUFFET BREATH GUARDS					
Buffet breath guard	36300	36301	36302	36303	98607
NSF 2 buffet breath guard	N36300	N36301	N36302	N36303	N98607
ACCESS® BREATH GUARDS					
Access® buffet, adjustable*	36339	36343	36363	36373	—
NSF 2 Access® buffet, adjustable*	N36339	N36343	N36363	N36373	—
Access® buffet, nonadjustable	36337	36341	36361	36371	9860206
NSF 2 Access® buffet, nonadjustable	N36337	N36341	N36361	N36371	N9860206

Note: To order stand-alone breath guards, add "RPL" to end of item number.

Light and Heat Strips

- Master on/off switch
- Stainless steel mounting assembly
- Incandescent/infrared accepts standard base incandescent bulbs or heat lamps up to 250W; cone-shaped reflector shields concentrate heat over well
- Clear plastic tube shield for fluorescent lights
- Heat strips cannot be specified for double-shelf cafeteria breath guard
- Access® adjustable breath guards have 9" to 15" (22.9 to 38.1 cm) serving opening height adjustment



DESCRIPTION	ITEM # ENTRÉE UNIT	ITEM # L: 46 IN (117 CM)	ITEM # L: 60 IN (152 CM)	ITEM # L: 74 IN (188 CM)	ITEM # L: 88 IN (224 CM)
Incandescent/infrared*	36440	36431	36432	36433	98625
Fluorescent*		36421	36422	36423	98622
Heat strip		36401	36402	36403	98623
Heat strip with lights*		36411	36412	36413	98624

*Bulbs and lamps not supplied – order separately.
White 250W Bulb – Item 72242. Red 500W Bulb – Item 72241.



4-Series Front-of-House Accessories

Storage Modules

- 300 series stainless steel
- Available with 34" (86.4 cm) high bases only
- With or without doors; key lock for sliding doors standard
- Opening height of module is: 16½" (42 cm)
- Depth: 25¼" (64.8 cm)
- Sizing may vary based on unit size and modifications



DESCRIPTION	WIDTH: IN (CM)	ITEM# W/ DOORS	ITEM# W/O DOORS
Fits 3-well hot, 60" (152.4 cm) cold, 46" (116.8 cm) beverage	24 (61)	36930	36931
Fits 4-well hot, 46" (116.8 cm) utility, 74" (188 cm) cold, 60" (152.4 cm) beverage	36 (91.4)	36936	36937
Fits 5-well hot, 60" (152.4 cm) utility, 74" (188 cm) beverage	50 (127)	36938	36939
Fits 6-well hot, 74" (188 cm) utility station	64 (162.6)	36940	36941
Fits 88" (224 cm) utility station	64 (162.6)	36938-2	36939-2



Bag in Box

- Stainless or galvanized shelf options
- Stainless steel door frame
- Open storage without doors provides easy access
- 16¾" H x 24¾" D (Width varies based on unit and internal clearance; opening varies based on equipment)



STAINLESS ITEM #	GALVANIZED ITEM #	LENGTH: IN (CM)	CASE LOT
36981	36982	46 (116.8)	1
36983	36984	60 (152.4)	1
36985	36986	74 (188)	1
98790	—	88 (224)	1

Note: Signature Server® equipment orders cannot be canceled or returned



Plate Rest

- Overall width: 7" (17.8 cm)
- Locking tabs on ends
- Removable without tools for easy transport
- Fold-down mounting kit
- Add 4" (10.16 cm) to width of unit in folded position



DESCRIPTION	ITEM # L: 28 IN (71 CM)	ITEM # L: 46 IN (117 CM)	ITEM # L: 60 IN (152 CM)	ITEM # L: 74 IN (188 CM)	ITEM # L: 88 IN (224 CM)
Plate rest with mounting kit	37511	37512	37513	37514	98829



ITEM #	DESCRIPTION
37509	Corner station plate rest – inside corner
37510	Corner station plate rest – outside corner

Tray Slides

- 300 series stainless steel
- Width: 12" (30.5 cm)
- Tray surface width: 11½" (29 cm)
- Removable for easy transport
- Fold-down mounting kit
- Four inverted “V” ribs on surface of V-rib models



DESCRIPTION	ITEM # L: 28 IN (71 CM)	ITEM # L: 46 IN (117 CM)	ITEM # L: 60 IN (152 CM)	ITEM # L: 74 IN (188 CM)	ITEM # L: 88 IN (224 CM)
18-gauge V-rib tray slides	37521	37522	37523	37524	98831
14-gauge V-rib slides	–	270280114-2	270290114-2	270300114-2	270310114-2
Tubular tray slides	9882001	9882003	9882004	9882005	9882006



ITEM #	DESCRIPTION
37519	Corner station V-rib tray slide – inside corner
37520	Corner station V-rib tray slide – outside corner
9882007	Corner station tubular tray slide – inside corner
9882008	Corner station tubular tray slide – outside corner

Cutting Board

- Fold-down mounting brackets
- Overall width: 8" (20.3 cm)
- Maple hardwood or polyethylene construction
- Adds 4" (10.2 cm) to width of unit when folded



DESCRIPTION	ITEM # LENGTH: 46 IN (117 CM)	ITEM # LENGTH: 60 IN (152 CM)	ITEM # LENGTH: 74 IN (188 CM)	ITEM # LENGTH: 88 IN (224 CM)
Wood	37551	37552	37553	98851
Poly	37561	37562	37563	98852

Note: Signature Server® equipment orders cannot be canceled or returned





End Shelf

- 300 series stainless steel
- 40 lb (18.2 kg) capacity
- Fold-down mounting kit
- Add 4½" (11.4 cm) to length of unit in folded position
- Not recommended for attachment to entrée cart, cashier station, or 28" (71 cm) utility station



ITEM #	DESCRIPTION	DIMENSIONS (W X D): IN (CM)
37570	18-gauge end shelf	18 x 28 (46 x 71)



Perforated False Bottoms

- 300 series stainless steel
- Maintains ice longer
- 1" (2.5 cm) above well bottom
- Perforated for easy draining



ITEM #	DESCRIPTION	WIDTH: IN (CM)
36913-2	Combination hot/cold food station	24 (61)
36914-2	Cold food station	46 (116.8)
36915-2	Cold food station	60 (152.4)
36916-2	Cold food station	74 (188)
98855-5	Cold food station	88 (224)

Stationary Legs

- Stainless steel
- Adjustable for leveling



ITEM #	DESCRIPTION
36921	Adjustable 4"-5" (10.2-12.7 cm)
2897451-2	4" (10.2 cm) leg
2897452-2	6" (15.2 cm) leg



Downdraft Vent System

with induction & fire suppression 6-Series or 4-Series designs

TAKE YOUR COOKING ANYWHERE

Elevate your guest dining experience to a whole new level with this award-winning mobile induction-cooking station. With integrated downdraft venting, fire containment and fire suppression, it sets the stage for unique, fresh, front-of-the-house cooking possibilities whenever and wherever you want them.



Integrated ANSUL fire suppression with fire containment food guard

Stainless steel top shelf and housing

6 mm tempered glass breath guard, available in 18" and 22" heights, provides a clear view of demo cooking

Stainless steel grease filter vents

Particulate filters at counter level (located under grease filters)

Various countertop types: laminate, stainless steel, acrylic solid surface or quartz to fit your design

Available with one or two induction ranges (One range ships with cutting board on countertop)

Customer and operator side accessories (plate rests, cutting boards and tray slides)

Main power and system switches

Fire suppression manual override

ANSUL container and system component storage

Laminate or stainless steel base finish

Casters and adjustable legs

Individual induction range controls

Removable stainless steel toe kick available on V-Class models

Stainless steel base construction



Downdraft Vent Module

- Meets industry requirements for equipment and fire safety
- Ideal for made-to-order pasta, stir fry, omelets and dessert stations
- UL710B certified downdraft venting system
- V-Class: stainless steel tubular frame construction
- V-Class: stainless steel toe kick (field assembly required)
- Signature Server®: reinforced 18-gauge 400 series stainless steel unibody
- 6-foot power cord



ITEM #	DESCRIPTION	PLUG
6-SERIES CUSTOM BASE WITH FOOD GUARD		
69718S-1-VCL	1 hob, operator left, 18" high food guard	5-15P
69718S-1-VCR	1 hob, operator right, 18" high food guard	5-15P
69718S-2-VC	2 hobs, 18"-high food guard	5-30P
69722S-1-VCL	1 hob, operator left, 22" high food guard	5-15P
69722S-1-VCR	1 hob, operator right, 22" high food guard	5-15P
69722S-2-VC 2	2 hobs, 22" high food guard	5-30P
4-SERIES BASE WITH FOOD GUARD		
69718S-2-SL	1 hob, operator left, 18" high food guard	5-15P
69718S-1-SR	1 hob, operator right, 18" high food guard	5-15P
69718S-2-S	2 hobs, 18" high food guard	5-30P
69722S-1-SL	1 hob, operator left, 22" high food guard	5-15P
69722S-1-SR	1 hob, operator right, 22" high food guard	5-15P
69722S-2-S	2 hobs, 22" high food guard	5-30P

FLEXVENT™ SLIDE-IN WITH DOWNDRAFT VENT SYSTEM AND FIRE SUPPRESSION

PAGES 32-33





2-Series Front-of-House

Our 2-Series front-of-house serving lines offer a great value in serving systems.



2-Series Front-of-House Station Function

2-Series Hot Food Stations Deluxe

- Stainless steel work surface
- Vinyl clad carbon steel base
- Choice of cafeteria or buffet breath guards
- Choose from seven standard colors
- 24" unit depth, sealed thermoset well with 480W direct contact heating element
- 120V or 208-240V options
- No spillage pans
- Thermostatic controls
- NSF 2 breath guards



DESCRIPTION	DIMENSIONS (L X H): IN (CM)	WALNUT WOODGRAIN ITEM #	CHERRY WOODGRAIN ITEM #	BRUSHED ALUMINUM ITEM #	GRANITE ITEM #	BLACK ITEM #
3-WELL HOT FOOD STATION – 120V						
Solid base**	46 x 35 (117 x 89)	T38935	T38767	T38727A	T38727	T38707
Solid w/lights+	46 x 35 (117 x 89)	T3893546	T3876746	T3872746A	T3872746	T3870746
Open storage**	46 x 35 (117 x 89)	T38936	T38768	T38728A	T38728	T38708
Open w/lights+	46 x 35 (117 x 89)	T3893646	T3876846	T3872846A	T3872846	T3870846
Storage w/door**	46 x 35 (117 x 89)	T38937	T38769	T38729A	T38729	T38709
Storage w/door, w/lights+	46 x 35 (117 x 89)	T3893746	T3876946	T3872946A	T3872946	T3870946
Cafeteria unit***	46 x 35 (117 x 89)	T39935	T39767	T39727A	T39727	T39707
Cafeteria unit w/open storage***	46 x 35 (117 x 89)	T39936	T39768	T39728A	T39728	T39708
Cafeteria unit w/storage door***	46 x 35 (117 x 89)	T39937	T39769	T39729A	T39729	T39709
4-WELL HOT FOOD STATION – 120V						
Solid base**	60 x 35 (152 x 89)	T38945	T38770	T38730A	T38730	T38710
Solid w/lights+	60 x 35 (152 x 89)	T3894560	T3877060	T3873060A	T3873060	T3871060
Open storage**	60 x 35 (152 x 89)	T38946	T38771	T38731A	T38731	T38711
Open w/lights+	60 x 35 (152 x 89)	T3894660	T3877160	T3873160A	T3873160	T3871160
Storage w/door**	60 x 35 (152 x 89)	T38947	T38772	T38732A	T38732	T38712
Storage w/door, w/lights+	60 x 35 (152 x 89)	T3894760	T3877260	T3873260A	T3873260	T3871260
Cafeteria unit***	60 x 35 (152 x 89)	T39945	T39770	T39730A	T39730	T39710
Cafeteria unit w/open storage***	60 x 35 (152 x 89)	T39948	T39771	T39731A	T39731	T39711
Cafeteria unit w/storage door***	60 x 35 (152 x 89)	T39947	T39772	T39732A	T39732	T39712

*Overall depth with breath guard: 39½" (100 cm) **For 208-240V without lights, add 2 to the model number ***Includes cafeteria breath guard with acrylic panel
 +For 120/208-240V units with lights, add 4 to the model number





2-Series Refrigerated Cold Food Stations

- Stainless steel work surface
- Vinyl clad carbon steel base
- Choice of cafeteria or buffet breath guards
- Choose from seven standard colors
- 24" unit depth, standard mechanically cooled well
- Foamed-in-place polyurethane foam insulation
- 120V
- 1" drain, NSF 2 breath guards



DESCRIPTION	DIMENSIONS (L X H): IN (CM)	WALNUT WOODGRAIN ITEM #	CHERRY WOODGRAIN ITEM #	BRUSHED ALUMINUM ITEM #	GRANITE ITEM #	BLACK ITEM #
46" COLD FOOD STATION BASE – 120V						
Solid base	46 x 35 (117 x 89)	R38950	R38773	R38733A	R38733	R38713
Solid w/lights	46 x 35 (117 x 89)	R3895046	R3877346	R3873346A	R3873346	R3871346
Open storage	46 x 35 (117 x 89)	R38951	R38774	R38734A	R38734	R38714
Open w/lights	46 x 35 (117 x 89)	R3895146	R3877446	R3873446A	R3873446	R3871446
Storage w/door	46 x 35 (117 x 89)	R38952	R38775	R38735A	R38735	R38715
Storage w/door, w/lights	46 x 35 (117 x 89)	R3895246	R3877546	R3873546A	R3873546	R3871546
Cafeteria unit**	46 x 35 (117 x 89)	R39950	R39773	R39733A	R39733	R39713
Cafeteria unit w/open storage**	46 x 35 (117 x 89)	R39951	R39774	R39734A	R39734	R39714
Cafeteria unit w/storage door**	46 x 35 (117 x 89)	R39952	R39775	R39735A	R39735	R39715
60" COLD FOOD STATION BASE – 120V						
Solid base	60 x 35 (152 x 89)	R38960	R38776	R38736A	R38736	R38716
Solid w/lights	60 x 35 (152 x 89)	R3896060	R3877660	R3873660A	R3873660	R3871660
Open storage	60 x 35 (152 x 89)	R38961	R38777	R38737A	R38737	R38717
Open w/lights	60 x 35 (152 x 89)	R3896160	R3877760	R3873760A	R3873760	R3871760
Storage w/door	60 x 35 (152 x 89)	R38962	R38778	R38738A	R38738	R38718
Storage w/door, w/lights	60 x 35 (152 x 89)	R3896260	R3877860	R3873860A	R3873860	R3871860
Cafeteria unit**	60 x 35 (152 x 89)	R39959	R39776	R39736A	R39736	R39716
Cafeteria unit w/open storage**	60 x 35 (152 x 89)	R39961	R39777	R39737A	R39737	R39717
Cafeteria unit w/storage door**	60 x 35 (152 x 89)	R39962	R39778	R39738A	R39738	R39718

Note: 2-Series equipment orders cannot be canceled or returned

*Overall depth with breath guard: 39½" (100 cm)

**Includes cafeteria breath guard with acrylic panel





2-Series Hot Food Stations

- Stainless steel work surface
- Vinyl clad carbon steel base
- Choice of cafeteria or buffet breath guards
- Choose from seven standard colors
- 24" unit depth, spillage pans required
- 120V or 208-240V options
- Spillage pans required, sold separately
- Infinite controls



DESCRIPTION	DIMENSIONS (L X H): IN (CM)	WALNUT WOODGRAIN ITEM #	CHERRY WOODGRAIN ITEM #	BRUSHED ALUMINUM ITEM #	GRANITE ITEM #	BLACK ITEM #
3-WELL HOT FOOD STATION – 120V						
Solid base*	46 x 35 (117 x 89)	38935	38767	38727A	38727	38707
Solid w/lights+	46 x 35 (117 x 89)	3893546	3876746	3872746A	3872746	3870746
Open storage*	46 x 35 (117 x 89)	38936	38768	38728A	38728	38708
Open w/lights+	46 x 35 (117 x 89)	3893646	3876846	3872846A	3872846	3870846
Storage w/door*	46 x 35 (117 x 89)	38937	38769	38729A	38729	38709
Storage w/door, w/lights+	46 x 35 (117 x 89)	3893746	3876946	3872946A	3872946	3870946
Cafeteria unit* **	46 x 35 (117 x 89)	39935	39767	39727A	39727	39707
Cafeteria unit w/open storage* **	46 x 35 (117 x 89)	39936	39768	39728A	39728	39708
Cafeteria unit w/storage door* **	46 x 35 (117 x 89)	39937	39769	39729A	39729	39709
4-WELL HOT FOOD STATION – 120V						
Solid base*	60 x 35 (152 x 89)	38945	38770	38730A	38730	38710
Solid w/lights+	60 x 35 (152 x 89)	3894560	3877060	3873060A	3873060	3871060
Open storage*	60 x 35 (152 x 89)	38946	38771	38731A	38731	38711
Open w/lights+	60 x 35 (152 x 89)	3894660	3877160	3873160A	3873160	3871160
Storage w/door*	60 x 35 (152 x 89)	38947	38772	38732A	38732	38712
Storage w/door, w/lights+	60 x 35 (152 x 89)	3894760	3877260	3873260A	3873260	3871260
Cafeteria unit* **	60 x 35 (152 x 89)	39945	39770	39730A	39730	39710
Cafeteria unit w/open storage* **	60 x 35 (152 x 89)	39948	39771	39731A	39731	39711
Cafeteria unit w/storage door* **	60 x 35 (152 x 89)	39947	39772	39732A	39732	39712

*For 208-240V without lights, add 2 to the model number **Includes cafeteria breath guard with acrylic panel +For 120/208-240V units with lights, add 4 to the model number





2-Series Cold Food Stations

- Stainless steel work surface
- Vinyl clad carbon steel base
- Choice of cafeteria or buffet breath guards
- Choose from seven standard colors
- 24" unit depth, spillage pans required
- 120V or 208-240V options
- Spillage pans required, sold separately
- Infinite controls
- Non-NSF 2 breath guards



DESCRIPTION	DIMENSIONS (L X H): IN (CM)	WALNUT WOODGRAIN ITEM #	CHERRY WOODGRAIN ITEM #	BRUSHED ALUMINUM ITEM #	GRANITE ITEM #	BLACK ITEM #
46" COLD FOOD STATION BASE – 120V						
Solid base	46 x 35 (117 x 89)	38950	38773	38733A	38733	38713
Solid w/lights	46 x 35 (117 x 89)	3895046	3877346	3873346A	3873346	3871346
Open storage	46 x 35 (117 x 89)	38951	38774	38734A	38734	38714
Open w/lights	46 x 35 (117 x 89)	3895146	3877446	3873446A	3873446	3871446
Storage w/door	46 x 35 (117 x 89)	38952	38775	38735A	38735	38715
Storage w/door, w/lights	46 x 35 (117 x 89)	3895246	3877546	3873546A	3873546	3871546
Cafeteria unit**	46 x 35 (117 x 89)	39950	39773	39733A	39733	39713
Cafeteria unit w/open storage**	46 x 35 (117 x 89)	39951	39774	39734A	39734	39714
Cafeteria unit w/storage door**	46 x 35 (117 x 89)	39952	39775	39735A	39735	39715
60" COLD FOOD STATION BASE – 120V						
Solid base	60 x 35 (152 x 89)	38960	38776	38736A	38736	38716
Solid w/lights	60 x 35 (152 x 89)	3896060	3877660	3873660A	3873660	3871660
Open storage	60 x 35 (152 x 89)	38961	38777	38737A	38737	38717
Open w/lights	60 x 35 (152 x 89)	3896160	3877760	3873760A	3873760	3871760
Storage w/door	60 x 35 (152 x 89)	38962	38778	38738A	38738	38718
Storage w/door, w/lights	60 x 35 (152 x 89)	3896260	3877860	3873860A	3873860	3871860
Cafeteria unit**	60 x 35 (152 x 89)	39959	39776	39736A	39736	39716
Cafeteria unit w/open storage**	60 x 35 (152 x 89)	39961	39777	39737A	39737	39717
Cafeteria unit w/storage door**	60 x 35 (152 x 89)	39962	39778	39738A	39738	39718

Note: 2-Series equipment orders cannot be canceled or returned *Overall depth with breath guard: 39½" (100 cm) **Includes cafeteria breath guard with acrylic panel





2-Series Utility Stations

- Stainless steel work surface
- Vinyl clad carbon steel base
- Choice of cafeteria or buffet breath guards
- Choose from seven standard colors
- 24" unit depth, ideal for dispensers or countertop equipment



DESCRIPTION	DIMENSIONS (L X H): IN (CM)	WALNUT WOODGRAIN ITEM #	CHERRY WOODGRAIN ITEM #	BRUSHED ALUMINUM ITEM #	GRANITE ITEM #	BLACK ITEM #
46" UTILITY STATION – 120V						
Solid base	46 x 35 (117 x 89)	38926	38761	38701A	38701	38701
Solid w/lights	46 x 35 (117 x 89)	3892646	3876146	3870146A	3870146	3870146
Open storage	46 x 35 (117 x 89)	38927	38762	38702A	38702	38702
Open w/lights	46 x 35 (117 x 89)	3892746	3876246	3870246A	3870246	3870246
Storage w/door	46 x 35 (117 x 89)	38928	38763	38703A	38703	38703
Storage w/door, w/lights	46 x 35 (117 x 89)	3892846	3876346	3870346A	3870346	3870346
Cafeteria unit**	46 x 35 (117 x 89)	39926	39761	39701A	39701	39701
Cafeteria unit w/open storage**	46 x 35 (117 x 89)	39927	39762	39702A	39702	39702
Cafeteria unit w/storage door**	46 x 35 (117 x 89)	39928	39763	39703A	39703	39703
60" UTILITY STATION – 120V						
Solid base	60 x 35 (152 x 89)	38930	38764	38724A	38724	38704
Solid w/lights	60 x 35 (152 x 89)	3893060	3876460	3872460A	3872460	3870460
Open storage	60 x 35 (152 x 89)	38931	38765	38725A	38725	38705
Open w/lights	60 x 35 (152 x 89)	3893160	3876560	3872560A	3872560	3870560
Storage w/door	60 x 35 (152 x 89)	38932	38766	38726A	38726	38706
Storage w/door, w/lights	60 x 35 (152 x 89)	3893260	3876660	3872660A	3872660	3870660
Cafeteria unit**	60 x 35 (152 x 89)	39930	39764	39724A	39724	39704
Cafeteria unit w/open storage**	60 x 35 (152 x 89)	39931	39765	39725A	39725	39705
Cafeteria unit w/storage door**	60 x 35 (152 x 89)	39932	39766	39726A	39726	39706

*Overall depth with breath guard: 39½" (100 cm)

**Includes cafeteria breath guard with acrylic panel



Cashier Station

- Stainless steel work surface
- Vinyl clad carbon steel base
- Choice of cafeteria or buffet breath guards
- Choose from seven standard colors
- 24" unit depth, cash drawer not available
- Open base with bottom shelf



COLOR	DIMENSIONS (W X D X H): IN (CM)	ITEM #
CASHIER STATION		
Black	24 x 24 x 35 (60.9 x 60.9 x 89)	38700
Granite	24 x 24 x 35 (60.9 x 60.9 x 89)	38720
Walnut woodgrain	24 x 24 x 35 (60.9 x 60.9 x 89)	38905
Cherry woodgrain	24 x 24 x 35 (60.9 x 60.9 x 89)	38760
Brushed aluminum	24 x 24 x 35 (60.9 x 60.9 x 89)	38720A





2-Series Front-of-House Color

Choose from five standard colors. Each seamlessly integrates into an environment – select whatever best matches your brand, business, and overall look and feel.



GRANITE

WALNUT
WOODGRAIN

BLACK

CHERRY
WOODGRAINBRUSHED
ALUMINUM

2-Series Front-of-House Breath Guards

Vollrath's line of breath guards effectively provides a stylish barrier between the customer and the prepared food in order to prevent potential contamination and maintain a healthy environment for both customers and the foodservice staff.



BUFFET



CAFETERIA



2-Series Front-of-House Storage Function

Whether you're a cashier needing to store valuables, a hot or cold service bar that needs storage for extra supplies, or a cafeteria foodservice line where no storage is required, we have a solution.



OPEN STORAGE



STORAGE WITH DOOR



NONE



2-Series Front-of-House Accessories

Plate Rests

- 18-gauge stainless steel
- Designed for 2-Series only
- Surface width: 7" (17.8 cm)
- Removable



ITEM #	DESCRIPTION	CASE LOT
38992*	24" (61 cm) plate rest with mounting kit	1
38993*	46" (117 cm) plate rest with mounting kit	1
38994*	60" (152 cm) plate rest with mounting kit	1

*Add NF in front of the item number for non-folding model

Tray Slides and Cutting Boards

- Polyethylene cutting boards
- 18-gauge 300 series stainless tray slide
- Fold-down mounting brackets
- Cutting boards add 4" (10.2 cm) and tray slides add 5½" (14 cm) to width of unit in folded position



TRAY SLIDE ITEM #	CUTTING BOARD ITEM #	DESCRIPTION	CASE LOT
39924*	39824*	Fits 24" (61 cm)	1
39946*	39846*	Fits 46" (117 cm)	1
39960*	39860*	Fits 60" (152 cm)	1

Note: Affordable Portable™ equipment orders cannot be canceled or returned
*Add NF in front of the item number for non-folding model

Spillage Pans

- Stainless steel or aluminum
- Accepts standard size pans
- Suitable for bulk storage
- Can use with adaptor plates or insets



ITEM #	DESCRIPTION	DIMENSIONS (L X W X D): IN (CM)	CASE LOT
99765	Standard edge stainless steel	19.8 x 11.9 x 6.4 (50.3 x 30.2 x 16.3)	1
99780	Dripless stainless steel	19.8 x 11.9 x 6.6 (50.3 x 30.2 x 16.8)	1
99785	Aluminum	19.9 x 11.9 x 6.4 (50.5 x 30.2 x 16.3)	1



6-Series Back-of-House

CUSTOM MANUFACTURED

Vollrath's line of durable 6-Series serving systems brings rugged beauty to the commercial kitchen. Chefs can customize their ideal back-of-house serving system, choosing from hot food stations, cold food stations, prep stations, work counters and sink stations. Everything is fully customizable – choose your preferred configurations and features.





Solid Stainless Steel



An industry favorite, our heavy-gauge stainless steel offers flexibility, durability and long-term value while maintaining a clean appearance. Major advantages

include its high corrosion resistance and ability to withstand fire and heat. As they say, if you can't take the heat, get out of the kitchen.

Our stainless fabrication is only limited by the imagination. Some call it the "back-of-house," but the complexity of fabrication is not at the back of anything. Some items include:

- 3-compartment sinks
- Bains-marie
- Bar tops
- Breath guards
- Cabinets
- Canopies
- Chef counters
- Condensate hoods
- Custom anything
- Dish tables
- Drawers
- Drink rails
- Elevator trims
- Equipment stands
- Escalator claddings
- Floor troughs
- Foot rails
- Mobile carts
- Prep tables
- Shelves
- Sinks
- Rack shelves
- Vent ducts
- Wall cabinets
- Wall cladding
- Work counters
- Worktables
- And more

Back-of-House Custom Fabrication

We offer extensive craftsmanship options that enable us to make all your projects come to life with details that not many are capable of executing in-house. Think of integral corners, leg cutting and edge detailing, fully welded framework, cross-bracing and under shelves, aprons to hide components like sinks, drop-ins and controls, and so much more.





4-Series Back-of-House

ASSORTED CUSTOMIZABLE OPTIONS

4-Series back-of-house stainless steel worktables offer predesigned configurations that fit several sizes, shapes, and material options to add flexibility to your foodservice operation. While they are not completely customizable, they do offer custom fabrication and some modifications, including shelving, sinks, cabinets and backsplash.



Back of House Prep & Worktable

Choose from worktable, prep tables and enclosed base designs

- Standard features include:
 - All stainless steel construction
 - All welded construction
 - Adjustable leveling legs
 - Cross bracing and support

Vollrath offers options to customize your worktable to fit almost any application. To customize your worktable, contact your Vollrath representative or visit vollrathfoodservice.com.



Choose the Countertop Gauge

Enjoy the durability and visual appeal of stainless steel with your choice of heavy-duty 14-gauge or standard 16-gauge countertop options.



Durable 14-gauge heavy-duty stainless steel is as durable as it is aesthetically pleasing.



Standard 16-gauge countertop adds strength and maintains all the beauty of stainless steel.

Open Base Stainless Steel Worktable



1 CHOOSE LENGTH (L)

LENGTH: IN	MODEL
36	SS-4WT-36
48	SS-4WT-48
60	SS-4WT-60
72	SS-4WT-72
84	SS-4WT-84
96	SS-4WT-96
108	SS-4WT-108
120	SS-4WT-120
132	SS-4WT-132
144	SS-4WT-144

2 CHOOSE DEPTH (W)

DEPTH: IN	SUFFIX
24	24
30	30
36	36

3 CHOOSE COUNTER GAUGE

GAUGE	SUFFIX
16	16
14	14

4 CHOOSE BASE CONFIGURATION

OPTIONS	SUFFIX
Open base, no bottom shelf, no backsplash	-OOF
Open base, no bottom shelf, with backsplash	-OOR
Open base, with bottom shelf, no backsplash	-OBF
Open base, with bottom shelf, with backsplash	-OBR



EXAMPLE CONFIGURED ITEM NUMBER

The sample item number below is an 48" x 24" open base worktable with 16-gauge top, no bottom shelf or backsplash.

Example item#: SS-4WT-482416-OOF



Open Base Stainless Steel Worktable With Sink



1 CHOOSE LENGTH (L)

LENGTH: IN	MODEL
36	SS-4PT-36
48	SS-4PT-48
60	SS-4PT-60
72	SS-4PT-72
84	SS-4PT-84
96	SS-4PT-96
108	SS-4PT-108
120	SS-4PT-120
132	SS-4PT-132
144	SS-4PT-144

2 CHOOSE DEPTH (W)

DEPTH: IN	SUFFIX
30	30
36	36

3 CHOOSE COUNTER GAUGE

GAUGE	SUFFIX
16	16
14	14

4 CHOOSE BOTTOM SHELF

SHELF	SUFFIX
None	-O
Bottom Shelf	-B

5 CHOOSE SINK POSITION

POSITION	SUFFIX
Right	R
Left	L
Center	C

1 2 3 4 5
SS-4PT-48 30 16 -O R
Length Depth Gauge Shelf Sink

EXAMPLE CONFIGURED ITEM NUMBER

The sample item number below is an 48" x 30" open base worktable with 16-gauge top, no bottom shelf, sink right. Example item#: SS-4PT-483016-OR

Enclosed Base Stainless Steel Worktable



1 CHOOSE LENGTH (L)

LENGTH: IN	MODEL
36	SS-4WT-36
48	SS-4WT-48
60	SS-4WT-60
72	SS-4WT-72
84	SS-4WT-84
96	SS-4WT-96
108	SS-4WT-108
120	SS-4WT-120
132	SS-4WT-132
144	SS-4WT-144

2 CHOOSE DEPTH (W)

DEPTH: IN	SUFFIX
24	24
30	30
36	36

3 CHOOSE COUNTER GAUGE

GAUGE	SUFFIX
16	16
14	14

4 CHOOSE BASE CONFIGURATION

OPTIONS	SUFFIX
Enclosed base, with bottom shelf, no backsplash	-EBF
Enclosed base, with bottom shelf, with backsplash	-EBR
Enclosed with door base, with bottom shelf, no backsplash	-DBF
Enclosed with door base, with bottom shelf, with backsplash	-DBR

Enclosed bases must have bottom shelf



EXAMPLE CONFIGURED ITEM NUMBER

The sample item number below is an 96" x 30" enclosed base worktable with 14-gauge top and bottom shelf, no backsplash.
Example item#: SS-4WT-963014-EBF



2-Series Back-of-House

Vollrath's 2-Series back-of-house serving systems — formerly known as ServeWell® — optimize your back-of-house food preparation. Choose from hot and cold food tables available in multiple configurations. These hot food stations use less energy than comparable models and concentrate energy within the wells to provide the best results.



Assembly required



Hot Food Tables*

- Thermoset wells cannot pit or rust
- Use standard adapter plates and insets for serving flexibility
- 38099: Optional caster set has four 4" (10.2 cm) swivel wheels – two with brakes
- Recommended for use with up to 4" (10.2 cm) deep full or fractional size pans; well depth is 6¼"

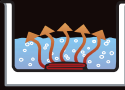

**DIRECT CONTACT HEATING SYSTEM:
NO VENTS = HIGH EFFICIENCY**
With a heating element in direct contact with the water and Vollrath's exclusive thermoset fiber-reinforced resin well, little heat is lost and the need for vents is eliminated

Dome elements transfer energy directly into water bath, eliminating the need for spillage pans

Four guide holes per side for breath guard attachment

7½" wide plate shelf with 8" wide cutting board standard on hot food unit

Equipped with standard 480W, 700W or 800W elements

Thermostatic controls

Each well is equipped with a brass drain valve



Brass Drain Valve

7½" wide plate shelf

Standard 10' power cord

Standard adjustable stationary legs or optional caster set



Low-water indicator light eliminates guesswork



Low-Water Indicator Light

Stainless steel construction includes legs and undershelf

ITEM #	DESCRIPTION	DIMENSIONS (W X D X H): IN (CM)	VOLTS**: AC	WATTS PER WELL	WATTS TOTAL	ELECTRICAL SERVICE (A)	AMPS	PLUG
700W/120V								
38102	2-well hot food table	32 x 32 x 34 (81.3 x 81 x 86)	120	700	1400	15	11.7	5-15P
38103	3-well hot food table	46 x 32 x 34 (116.8 x 81 x 86)	120	700	2100	30	17.5	5-30P
38104	4-well hot food table	61¼ x 32 x 34 (155.6 x 81 x 86)	120	700	2800	30	23.3	5-30P
38105	5-well hot food table	76 x 32 x 34 (193 x 81 x 86)	120	700	3500	50	29.2	5-50P
480W/120V								
38002	2-well hot food table	32 x 32 x 34 (81.3 x 81 x 86)	120	480	960	15	8	5-15P
38003	3-well hot food table	46 x 32 x 34 (116.8 x 81 x 86)	120	480	1440	15	12	5-15P
38004	4-well hot food table	61¼ x 32 x 34 (155.6 x 81 x 86)	120	480	1920	20	16	5-20P
38005	5-well hot food table	76 x 32 x 34 (193 x 81 x 86)	120	480	2400	30	20	5-30P
600-800W/208-240V								
38116	2-well hot food table	32 x 32 x 34 (81.3 x 81 x 86)	208-240	600-800	1200-1600	15	6.7	6-15P
38117	3-well hot food table	46 x 32 x 34 (116.8 x 81 x 86)	208-240	600-800	1800-2400	15	10	6-15P
38118	4-well hot food table	61¼ x 32 x 34 (155.6 x 81 x 86)	208-240	600-800	2400-3200	20	13.3	6-20P
38119	5-well hot food table	76 x 32 x 34 (193 x 81 x 86)	208-240	600-800	3000-4000	30	16.6	6-30P

*Dedicated circuit may be required for higher currents **Single phase only Note: ServeWell® hot food table orders cannot be canceled or returned





Streamlined Hot Food Tables

- Designed to hold heated prepared foods at temperatures above the HACCP “danger zone” of 140°F (60°C)
- Accept full-size or fractional pans to 4" (10.2 cm) deep, and can be used with standard adapter plates and insets for serving flexibility
- Thermoset fiber-reinforced resin wells are self-insulating for maximum energy efficiency – will not rust or pit
- Thermostatic heat controls
- Low-water indicator light eliminates guesswork
- Dome heating elements use up to 25% less energy and concentrate energy into the wells
- Nonstick surface on heating elements helps reduce scale buildup for easy cleaning and longer operating life
- 10-foot (3 m) power cord bottom-mounted
- Standard adjustable stationary legs or optional caster set
- Shipped knocked down
- Optional casters – 38099
- Optional cutting board



ITEM #	DESCRIPTION	DIMENSIONS (W X D H): IN (CM)	VOLTS**: AC	WATTS PER WELL	WATTS TOTAL	ELECTRICAL SERVICE (A)	AMPS	PLUG
480W/120V								
38203	3-well	46 x 29½ x 34 (116.8 x 74.9 x 86)	120	480	1440	15	12	5-15P
38204	4-well	61¼ x 29½ x 34 (155.6 x 74.9 x 86)	120	480	1920	20	16	5-20P
38205	5-well	76 x 29½ x 34 (193 x 74.9 x 86)	120	480	2400	30	20	5-30P
700W/120V								
38213	3-well	46 x 29½ x 34 (116.8 x 74.9 x 86)	120	700	2100	30	17.5	5-30P
38214	4-well	61¼ x 29½ x 34 (155.6 x 74.9 x 86)	120	700	2800	30	23.3	5-30P
38215	5-well	76 x 29½ x 34 (193 x 74.9 x 86)	120	700	3500	50	29.2	5-50P
600-800W/208-240V								
38217	3-well	46 x 29½ x 34 (116.8 x 74.9 x 86)	208-240	600-800	1800-2400	15	10	6-15P
38218	4-well	61¼ x 29½ x 34 (155.6 x 74.9 x 86)	208-240	600-800	2400-3200	20	13.3	6-20P
38219	5-well	76 x 29½ x 34 (193 x 74.9 x 86)	208-240	600-800	3000-4000	30	16.6	6-30P
OPTIONAL CUTTING BOARDS								
2342901	Cutting board	46½ x 6¼ (118.1 x 15.875)	—	—	—	—	—	—
2343101	Cutting board	61¼ x 6¼ (155.6 x 15.875)	—	—	—	—	—	—
2343201	Cutting board	76 x 6¼ (193 x 15.875)	—	—	—	—	—	—
OPTIONAL CASTER SET								
38099	Caster set, 4" (10.2 cm) swivel wheels, two with brakes	—	—	—	—	—	—	—

*Dedicated circuit may be required for higher currents **Single phase only Note: ServeWell® hot food table orders cannot be canceled or returned





Food Table Accessories

Option: buffet breath guard

Option: fixed plate rest on customer side

Option: caster set – 4" (10.2 cm) swivel wheels with brakes



Option: work/overshelf – single- or double-deck (without acrylic panel)

Option: single-deck cafeteria guard (with acrylic panel)



Note: Heat strips are not an option

Work/Single Overshelf Without Acrylic Panel*

ITEM #	DIMENSIONS (L X W X H): IN (CM)
38042	32 x 10 x 13 (81.3 x 25.4 x 33)
38043	46 x 10 x 13 (116.8 x 25.4 x 33)
38044	61¼ x 10 x 13 (155.6 x 25.4 x 33)
38045	76 x 10 x 13 (193 x 25.4 x 33)

Single-Deck Cafeteria Guards With Acrylic Panel*

ITEM #	DIMENSIONS (L X W X H): IN (CM)
38052	32 x 10 x 13 (81.3 x 25.4 x 33)
38053	46 x 10 x 13 (116.8 x 25.4 x 33)
38054	61¼ x 10 x 13 (155.6 x 25.4 x 33)
38055	76 x 10 x 13 (193 x 25.4 x 33)

Buffet Breath Guards*

ITEM #	DIMENSIONS (L X W X H): IN (CM)
38062	32 x 35¾ x 23½ (81.3 x 89.8 x 59.7)
38063	46 x 35¾ x 23½ (116.8 x 89.8 x 59.7)
38064	61¼ x 35¾ x 23½ (155.6 x 89.8 x 59.7)
38065	76 x 35¾ x 23½ (193 x 89.8 x 59.7)

Double-Deck Overshelf Without Acrylic Panel*

ITEM #	DIMENSIONS (L X W X H): IN (CM)
38032	32 x 10 x 26 (81.3 x 25.4 x 66)
38033	46 x 10 x 26 (116.8 x 25.4 x 66)
38034	61¼ x 10 x 26 (155.6 x 25.4 x 66)
38035	76 x 10 x 26 (193 x 25.4 x 66)

*For units only with 4 guide holes per side

Optional Customer Side Poly Cutting Boards With Mounting Kit* **

ITEM #	DIMENSIONS (L X W X H): IN (CM)
38072	32 x 8 x 1 (81.3 x 20.3 x 2.5)
38073	46 x 8 x 1 (116.8 x 20.3 x 2.5)
38074	61¼ x 8 x 1 (155.6 x 20.3 x 2.5)
38075	76 x 8 x 1 (193 x 20.3 x 2.5)

**Replacement part

Plate Rests

ITEM #	DIMENSIONS (L X W X H): IN (CM)
38092	32 x 8 x 1 (81.3 x 20.3 x 2.5)
38093	46 x 8 x 1 (116.8 x 20.3 x 2.5)
38094	61¼ x 8 x 1 (155.6 x 20.3 x 2.5)
38095	76 x 8 x 1 (193 x 20.3 x 2.5)

Caster Sets

ITEM #	DESCRIPTION
38099	4" caster set, two w/brakes
3809934	4" caster set, two w/brakes, ADA HT



How To Use Appendix

Alphabetical Index

Products are listed in alphabetical order. When searching, look for broad product categories followed by details. For example, if you're searching for a utility cart, look under "Carts, Utility."

Numerical Index

Item numbers starting with "0" shown first. Then numeric index is sorted by the number of digits (or numbers before-dash (-) or a letter, if applicable). Asterisk denotes incomplete item number. See page number for details.

ITEM..... PAGE

2-Series Front-of-House	80-86
2-Series Back-of-House	93-96
4-Series Front-of-House	70-77
4-Series Back-of-House	89-92
6-Series Front-of-House	61-69
6-Series Back-of-House	87-88

A

Accessories, 2-Series, Front-of-House	86
Accessories, 2-Series, Back-of-House	96
Accessories, 4-Series, Front-of-House	75-77
Accessories, 6-Series, Front-of-House	67
Accessories, Induction Dry Well Drop-Ins	15
Accessories, Round Induction Drop-Ins	17

B

Bag Dispensers	41
Bain-Marie Drop-Ins	21
Breath Guards	42-45
Breath Guards, 4-Series	73
Breath Guards, 6-Series	67
Breath Guards, Contemporary Style	43
Breath Guards, Stainless Steel Counters, 4-Series	74
Breath Guards, Traditional Style	42
Breath Guards, Velocity	44-45

C

Cashier Station, 2-Series	84
Cayenne® Drop-In Warmers	20
Cayenne® Hard Wired Heat Strips	48
Cayenne® Light Strips	47
Cold Drop-Ins	25-28
Cold Food Stations, 2-Series	83
Color and Texture Options, 4-Series	72
Construction Materials, 6-Series	61
Contemporary Style Breath Guards	43
Countertops, 4-Series	72
Countertops, 6-Series	64-65
Cup Dispensers	39

D

Décor Materials, 6-Series	62-63
Dispensers, Cup	39
Dispensers, In-Counter	29-41
Dispensers, Lid	38, 40
Dispensers, LidSaver™	38-39
Dispensers, Napkin	40-41
Dispensers, Straw	40
Display Cases, Drop-Ins	51
Downdraft Vent System	78-79
Drop-Ins, Bain-Marie	21
Drop-Ins, Display Cases	51
Drop-Ins, Hot/Cold Combination	29
Drop-Ins, Hot	18-24
Drop-Ins, Induction	12-17, 30-31
Drop-Ins, Nonrefrigerated	25-26
Drop-Ins, Refrigerated/Cold	25-28

ITEM..... PAGE

Drop-Ins, Refrigerated Frost Top	28
Drop-Ins, Short Side	22, 25-26
Drop-Ins, Soup	17
Drop-Ins, Warmers	20
Dry Well Drop-Ins	12-15

E

Enclosed Base Worktable, 4-Series, Back-of-House	92
Equipment, 6-Series	66

F

Fabricator Wells	10-11, 18
FlexVent™ Slide-In	32-33
Flush-Mount Dispensers	40-41
Forced Air Cold Drop-In	27

H

Heated Drop-In Display Cases	51
Heat and Light Strips	49
Heat and Light Strips, 4-Series	74
Heat Strips, Cayenne®	48
Heat Strips, Low-Profile	46
Heated Shelf Drop-Ins	50
Hot/Cold Combination Drop-Ins	29
Hot Drop-Ins	18-24
Hot Food Stations, 2-Series	82
Hot Food Stations Deluxe, 2-Series	80
Hot Food Tables, Back-of-House	94-95
Hot Well Drop-Ins	18-24

I

In-Counter Dispenser	38-41
Induction Drop-Ins	12-17, 30-31
Induction and Fire Suppression Vent System, Downdraft	78-79
Induction Ranges Drop-Ins	30-31

K

Knock Box	37
-----------------	----

L

Lid Dispensers	38, 40
LidSaver™ Dispensers	38-39
Light Strips, Cayenne®	47
Light and Heat Strips	49
Light and Heat Strips, 4-Series	74
Low-Profile Heat Strips	46

M

Marine-Grade Wells	22-24
Mirage® Drop-In Induction	31
Modular Drop-Ins	19, 21
ModuServ™ In-Counter Dispenser System	41
Modular Induction Dry Well Drop-Ins	12-15

N

Napkin Dispensers	40-41
Nonrefrigerated Drop-Ins	25-26
NSF 7 Drop-Ins	27-29

O

Open Base Worktable, 4-Series, Back-of-House	90
Open Base Worktable with Sink, 4-Series, Back-of-House	91

R

Rectangular Bases, 4-Series	70-71
Refrigerator Pan Drop-Ins	26-29
Refrigerated Drop-In Display Cases	51
Refrigerated Food Station, 2-Series	81
Refrigerated Frost Top	28
Refrigerated Slide-In, SerVue™	52-53
Round Induction Drop-Ins	17

S

Serving Lines, 2-Series	80-86
Serving Lines, 4-Series	70-77
Serving Lines, 6-Series	61-69
Serving Lines, Series Comparison	58-59
SerVue™ Touchless Refrigerated Slide-In	52-53
Shelf, Heated Drop-In	50
Short Side Drop-Ins	22, 25-26
Sinks	34-37
Soup Drop-Ins	17
Straw Dispensers	40
Streamlined Hot Food Tables, 2-Series, Back-of-House	95

T

Traditional Style Breath Guards	42
---------------------------------------	----

U

Utility Stations, 2-Series	84
----------------------------------	----

V

Velocity® Breath Guard	44-45
------------------------------	-------

W

Warmer Drop-Ins	20
Waste Chutes	36
Waste Receptacle Doors	41
Worktables, 4-Series, Back-of-House	90-92

ITEM.....	PAGE	ITEM.....	PAGE	ITEM.....	PAGE	ITEM.....	PAGE	ITEM.....	PAGE	ITEM.....	PAGE
1VW-A		36116.....	71	36367.....	70	36641.....	22	37030.....	70	38063.....	96
1VW-A.....	39	36117.....	71	36368.....	18	36642.....	22	37040.....	70	38064.....	96
1Y402.....	36	36120.....	71	36369.....	18	36643.....	22	37043.....	70	38065.....	96
3Y0502.....	36	36121.....	71	36371.....	74	36644.....	22	37045.....	70	38072.....	96
3Y0505.....	36	36122.....	71	36373.....	74	36645.....	22	37046.....	70	38073.....	96
5IPF25.....	15	36123.....	71	36377.....	70	36646.....	22	37047.....	70	38074.....	96
5IPF40.....	15	36125.....	71	36399.....	23	36647.....	22	37050.....	70	38075.....	96
5IPH25.....	15	36126.....	71	36400.....	23	36648.....	22	37057.....	70	38092.....	96
5IPH40.....	15	36127.....	71	36401.....	49, 74	36649.....	22	37060.....	70	38093.....	96
8Y802.....	36	36130.....	70	36402.....	49, 74	36650.....	22	37065.....	70	38094.....	96
101-1-1.....	34	36140.....	70	36403.....	49, 74	36651.....	22	37066.....	70	38095.....	96
101-1-2.....	34	36143.....	70	36404.....	23	36654.....	25	37067.....	70	38099.....	95, 96
102-1-1.....	34	36145.....	70	36405.....	23	36657.....	25	37070.....	70	38102.....	94
102-1-2.....	34	36146.....	70	36406.....	24	36660.....	25	37075.....	70	38103.....	94
120Y02.....	36	36150.....	70	36407.....	24	36680.....	72	37076.....	70	38104.....	94
		36160.....	70	36408.....	24	36681.....	72	37077.....	70	38105.....	94
131-8		36165.....	70	36409.....	24	36682.....	72	37085.....	71	38116.....	94
131-8.....	34	36166.....	70	36411.....	49, 74	36683.....	72	37091.....	70	38117.....	94
131-9.....	34	36170.....	70	36412.....	49, 74	36685.....	72	37095.....	70	38118.....	94
141-0.....	37	36175.....	70	36413.....	49, 74	36686.....	72	37310.....	74	38119.....	94
141-0C.....	37	36176.....	70	36421.....	49, 74	36687.....	72	37311.....	74		
155-4.....	36	36185.....	71	36422.....	49, 74	36688.....	72	37312.....	74	38203	
173-4-2.....	36	36191.....	70	36423.....	49, 74	36689.....	72	37313.....	74	38203.....	95
229-1.....	34	36195.....	70	36429R.....	28	36690.....	72	37320.....	74	38204.....	95
1410-0.....	37	36212.....	71	36430R.....	28	36691.....	72	37321.....	74	38205.....	95
1410CS.....	37	36213.....	71	36431.....	49, 74	36692.....	72	37322.....	74	38213.....	95
1410T.....	37	36214.....	71	36432.....	49, 74	36693.....	72	37323.....	74	38214.....	95
1411.....	37	36220.....	71	36433.....	49, 74	36694.....	72	37509.....	76	38215.....	95
1551.....	36	36221.....	71	36434R.....	28	36695.....	72	37510.....	76	38217.....	95
1554-C.....	36	36222.....	71	36436R.....	28	36696.....	72	37511.....	76	38218.....	95
1734-C.....	36	36223.....	71	36438R.....	28	36697.....	72	37512.....	76	38219.....	95
2004.....	37	36230.....	70	36440.....	49, 74	36913-2.....	77	37513.....	76	38700.....	84
2005.....	36	36240.....	70	36441R.....	27	36914-2.....	77	37514.....	76	38701.....	84
2612.....	36	36243.....	70	36442R.....	27	36915-2.....	77	37519.....	76	38701A.....	84
2613.....	37	36245.....	70	36444R.....	27	36916-2.....	77	37520.....	76	38702.....	84
6525-13.....	41	36250.....	70	36446R.....	27	36921.....	77	37521.....	76	38702A.....	84
6525-28.....	41	36260.....	70	36447.....	70	36930.....	75	37522.....	76	38703.....	84
6535-13.....	41	36265.....	70	36448R.....	27	36931.....	75	37523.....	76	38703A.....	84
7400P.....	36	36270.....	70	36450.....	26	36936.....	75	37524.....	76	38704.....	84
7466.....	37	36275.....	70	36451.....	26	36937.....	75	37551.....	76	38705.....	84
9101-1.....	35	36285.....	71	36452.....	26	36938.....	75	37552.....	76	38706.....	84
9102-1.....	35	36291.....	70	36453.....	26	36938-2.....	75	37553.....	76	38707.....	82
9103-1.....	35	36295.....	70	36454.....	26	36939.....	75	37561.....	76	38708.....	82
1010+0.....	35			36456R.....	28	36939-2.....	75	37562.....	76	38709.....	82
10101-1P.....	35			36457.....	70	36940.....	75	37563.....	76	38710.....	82
10102-1.....	35	36300	74	36462.....	21	36941.....	75	37570.....	77	38711.....	82
10103-1.....	35	36301.....	74	36463.....	21	36981.....	75			38712.....	82
12065-2.....	35	36302.....	74	36464.....	21	36982.....	75	38002	94	38713.....	83
12065-3.....	35	36303.....	74	36465.....	21	36983.....	75	38002.....	94	38714.....	83
1210+1.....	35	36337.....	74	36466.....	23	36984.....	75	38003.....	94	38715.....	83
12102-1.....	35	36339.....	74	36467.....	23	36985.....	75	38004.....	94	38716.....	83
12103-1.....	35	36341.....	74	36468.....	70	36986.....	75	38005.....	94	38717.....	83
12121-1.....	35	36343.....	74	36471.....	23			38032.....	96	38718.....	83
12122-1.....	35	36347.....	70	36472.....	23	37012		38033.....	96	38720.....	84
12123-1.....	35	36352.....	19	36473.....	23	37012.....	71	38034.....	96	38720A.....	84
12123-2.....	35	36353.....	19	36474.....	24	37013.....	71	38035.....	96	38724.....	84
1614+1.....	35	36354.....	19	36475.....	24	37014.....	71	38042.....	96	38724A.....	84
20000.....	15	36355.....	19	36476.....	24	37015.....	71	38043.....	96	38725.....	84
23236.....	49	36356.....	19	36490R.....	27	37020.....	71	38044.....	96	38725A.....	84
		36357.....	70	36491.....	26	37021.....	71	38045.....	96	38726.....	84
36112		36358.....	19			37022.....	71	38052.....	96	38726A.....	84
36112.....	71	36359.....	19	36500		37023.....	71	38053.....	96	38727.....	82
36113.....	71	36360.....	19	36500.....	21	37025.....	71	38054.....	96	38727A.....	82
36114.....	71	36361.....	74	36502.....	21	37026.....	71	38055.....	96	38728.....	82
36115.....	71	36363.....	74	36640.....	22	37027.....	71	38062.....	96	38728A.....	82

ITEM.....PAGE	ITEM.....PAGE	ITEM.....PAGE	ITEM.....PAGE	ITEM.....PAGE	ITEM.....PAGE	ITEM.....PAGE
38729.....82	39702.....84	39777.....83	69584.....30	97043.....71	1789760.....49	
38729A.....82	39702A.....84	39778.....83	69718S-1SR.....79	97045.....71	1789766.....49	
38730.....82	39703.....84	39824	69718S-1VCL.....79	97046.....71	1789772.....49	
38730A.....82	39703A.....84	39824.....86	69718S-1VCR.....79	97047.....71	2342901.....95	
38731.....82	39704.....84	39846.....86	69718S-2-S.....79	97050.....71	2343101.....95	
38731A.....82	39705.....84	39860.....86	69718S-2-SL.....79	97057.....71	2343201.....95	
38732.....82	39706.....84	39924.....86	69718S-2-VC.....79	97060.....71	2897451-2.....77	
38732A.....82	39707.....82	39926.....84	69722S-1-SL.....79	97061.....71	2897452-2.....77	
38733.....83	39708.....82	39927.....84	69722S-1-SR.....79	97065.....71	3639901	
38733A.....83	39709.....82	39928.....84	69722S-1-VCL.....79	97066.....71	3639901.....23	
38734.....83	39710.....82	39928.....84	69722S-1-VCR.....79	97067.....71	3639910.....23	
38734A.....83	39711.....82	39930.....84	69722S-2-S.....79	97070.....71	3639911.....23	
38735.....83	39712.....82	39931.....84	69722S-2-VC 2.....79	97075.....71	3639950.....23	
38735A.....83	39713.....83	39932.....84	72001	97076.....71	3639951.....23	
38736.....83	39714.....83	39935.....82	72001.....20	97077.....71	3639960.....23	
38736A.....83	39715.....83	39936.....82	72005.....20	97080.....71	3639961.....23	
38737.....83	39716.....83	39937.....82	72107.....20	97084.....71	3639970.....23	
38737A.....83	39717.....83	39945.....82	72109.....20	97085.....71	3639971.....23	
38738.....83	39718.....83	39946.....86	72111.....20	97086.....71	3639980.....23	
38738A.....83	39724.....84	39947.....82	72112.....20	97212.....71	3639981.....23	
38760.....84	39724A.....84	39948.....82	72560.....20	97215.....71	3640001.....23	
38761.....84	39725.....84	39950.....83	72610.....20	97216.....71	3640010.....23	
38762.....84	39725A.....84	39951.....83	72702.....48	97220.....71	3640011.....23	
38763.....84	39726.....84	39952.....83	72703.....48	97221.....71	3640050.....23	
38764.....84	39726A.....84	39959.....83	72705.....48	97222.....71	3640051.....23	
38765.....84	39727.....82	39960.....86	72706.....48	97223.....71	3640060.....23	
38766.....84	39727A.....82	39961.....83	72707.....48	97233.....71	3640061.....23	
38767.....82	39728.....82	39962.....83	72708.....48	98607.....74	3640070.....23	
38768.....82	39728A.....82	40842	72709.....48	98616.....72	3640071.....23	
38769.....82	39729.....82	40842.....51	72711.....48	98617.....72	3640080.....23	
38770.....82	39729A.....82	40843.....51	72712.....48	98622.....49, 74	3640081.....23	
38771.....82	39730.....82	40844.....51	72714.....48	98623.....49, 74	3640401.....23	
38772.....82	39730A.....82	40845.....51	72715.....48	98624.....49, 74	3640410.....23	
38773.....83	39731.....82	40846.....51	72717.....48	98625.....49, 74	3640441.....23	
38774.....83	39731A.....82	40847.....51	72718.....48	98707.....70	3640450.....23	
38775.....83	39732.....82	44140.....49	72720.....48	98708.....70	3640451.....23	
38776.....83	39732A.....82	44145.....49	72721.....48	98710.....70	3640460.....23	
38777.....83	39733.....83	44545.....49	72723.....48	98711.....71	3640461.....23	
38778.....83	39733A.....83	44546.....49	72724.....48	98790.....75	3640470.....23	
38905	39734.....83	47400.....17	72726.....48	98829.....76	3640471.....23	
38905.....84	39734A.....83	47488.....17	72727.....48	98831.....76	3640480.....23	
38926.....84	39735.....83	47491.....17	72729.....48	98835.....72	3640481.....23	
38927.....84	39735A.....83	47492.....17	72730.....48	98836.....72	3640501.....23	
38928.....84	39736.....83	47493.....17	72732.....48	98851.....76	3640510.....23	
38928.....84	39736A.....83	47494.....17	72733.....48	98852.....76	3640511.....23	
38930.....84	39737.....83	58814	74701D.....17	98855-5.....77	3640550.....23	
38931.....84	39737A.....83	58814.....30	74701DW.....17	98888.....70	3640551.....23	
38932.....84	39738.....83	59501.....31	75120.....15	99305.....71	3640560.....23	
38935.....82	39738A.....83	59502DW.....31	75210.....15	99765.....86	3640561.....23	
38936.....82	39761.....84	59508DW.....31	75220.....15	99780.....86	3640570.....23	
38937.....82	39762.....84	59601.....31	77250.....15	99785.....86	3640571.....23	
38945.....82	39763.....84	59602.....31	88184	201250	3640580.....23	
38946.....82	39764.....84	59603.....31	88184.....17	201250.....34	3640581.....23	
38947.....82	39765.....84	59605.....31	88184NS.....17	201260.....34	3640610.....24	
38950.....83	39766.....84	59641.....31	88204.....17	212560.....34	3640650.....24	
38951.....83	39767.....82	59642.....31	88204NS.....17	741101D.....17	3640660.....24	
38952.....83	39768.....82	59643.....31	97013	741101DW.....17	3640670.....24	
38960.....83	39769.....82	59645.....31	97013.....71	1789718.....49	3640680.....24	
38961.....83	39770.....82	69505	97014.....71	1789724.....49	3640701.....24	
38962.....83	39771.....82	69505.....30	97025.....71	1789730.....49	3640710.....24	
38992.....86	39772.....82	69508.....30	97026.....71	1789736.....49	3640711.....24	
38993.....86	39773.....83	69521.....30	97027.....71	1789742.....49	3640750.....24	
38994.....86	39774.....83	69524.....30	97030.....71	1789748.....49	3640751.....24	
39701.....84	39775.....83		97040.....71	1789754.....49	3640760.....24	
39701A.....84	39776.....83					

ITEM.....	PAGE	ITEM.....	PAGE	ITEM.....	PAGE	ITEM.....	PAGE	ITEM.....	PAGE	ITEM.....	PAGE
3640761.....	24	3647510.....	24	3872746.....	82	7286000		CB98640.....	43	FC-4HS-30120-SSF.....	50
3640770.....	24	3647550.....	24	3872746A.....	82	7286000.....	47	CB98650.....	43	FC-4HS-30120-SSR.....	50
3640771.....	24	3647560.....	24	3872846.....	82	7286002.....	47	CB98651.....	43	FC-4HS-36120-BKF.....	50
3640780.....	24	3647570.....	24	3872846A.....	82	7286100.....	47	CB98652.....	43	FC-4HS-36120-BKR.....	50
3640781.....	24	3647580.....	24	3872946.....	82	7286102.....	47	CB98653.....	43	FC-4HS-36120-SSF.....	50
3640801.....	24	3647610.....	24	3872946A.....	82	7286200.....	47	CB98654.....	43	FC-4HS-36120-SSR.....	50
3640810.....	24	3647650.....	24	3873060.....	82	7286202.....	47	CB98660.....	43	FC-4HS-42120-BKF.....	50
3640811.....	24	3647660.....	24	3873060A.....	82	7286300.....	47	CB98661.....	43	FC-4HS-42120-BKR.....	50
3640850.....	24	3647670.....	24	3873160.....	82	7286302.....	47	CB98662.....	43	FC-4HS-42120-SSF.....	50
3640851.....	24	3647680.....	24	3873160A.....	82	7286400.....	47	CB98663.....	43	FC-4HS-42120-SSR.....	50
3640860.....	24	3647700.....	70	3873260.....	82	7286402.....	47	E		FC-4HS-48120-BKF.....	50
3640861.....	24	3664020.....	22	3873260A.....	82	7286500.....	47	E6WC02.....	36	FC-4HS-48120-BKR.....	50
3640870.....	24	3664030.....	22	3873346.....	83	7286502.....	47	E9WC02.....	36	FC-4HS-48120-SSF.....	50
3640871.....	24	3664120.....	22	3873346A.....	83	7286600.....	47	E06064-KB.....	37	FC-4HS-48120-BKR.....	50
3640880.....	24	3664130.....	22	3873446.....	83	7286602.....	47	F		FC-4HS-54120-BKF.....	50
3640881.....	24	3664220.....	22	3873446A.....	83	7286700.....	47	FC-4C-01120-N.....	28	FC-4HS-54120-BKR.....	50
3640901.....	24	3664230.....	22	3873546.....	83	7286702.....	47	FC-4C-01120-R.....	27	FC-4HS-54120-SSF.....	50
3640910.....	24	3664320.....	22	3873546A.....	83	7286800.....	47	FC-4C-02120-F.....	28	FC-4HS-54120-SSR.....	50
3640911.....	24	3664330.....	22	3873660.....	83	7286802.....	47	FC-4C-02120-N.....	28	FC-4HS-60120-BKF.....	50
3640950.....	24	3664420.....	22	3873660A.....	83	7286900.....	47	FC-4C-02120-R.....	27	FC-4HS-60120-BKR.....	50
3640951.....	24	3664430.....	22	3873760.....	83	7286902.....	47	FC-4C-03120-F.....	28	FC-4HS-60120-SSF.....	50
3640960.....	24	3664520.....	22	3873760A.....	83	9860206		FC-4C-03120-FA.....	27	FC-4HS-60120-SSR.....	50
3640961.....	24	3664530.....	22	3873860.....	83	9860206.....	74	FC-4C-03120-N.....	28	FC-4HS-66120-BKF.....	50
3640970.....	24	3664620.....	22	3873860A.....	83	9861006.....	74	FC-4C-03120-R.....	27	FC-4HS-66120-BKR.....	50
3640971.....	24	3664630.....	22	3876146.....	84	9861707.....	74	FC-4C-04120-F.....	28	FC-4HS-66120-SSF.....	50
3640980.....	24	3664720.....	22	3876246.....	84	9882001.....	76	FC-4C-04120-N.....	28	FC-4HS-66120-SSR.....	50
3640981.....	24	3664730.....	22	3876346.....	84	9882003.....	76	FC-4C-04120-FA.....	27	FC-4HS-72120-BKF.....	50
3646210		3664820.....	22	3876460.....	84	9882004.....	76	FC-4C-04120-R.....	27	FC-4HS-72120-BKR.....	50
3646210.....	21	3664830.....	22	3876560.....	84	9882005.....	76	FC-4C-05120-F.....	28	FC-4HS-72120-SSF.....	50
3646310.....	21	3664920.....	22	3876660.....	84	9882006.....	76	FC-4C-05120-N.....	28	FC-4HS-72120-SSR.....	50
3646410.....	21	3664930.....	22	3876746.....	82	9882007.....	76	FC-4C-05120-R.....	27	FC-4SH.....	46
3646510.....	21	3665020.....	22	3876846.....	82	9882008.....	76	FC-4C-06120-F.....	28	FC-4TD-28120-C.....	53
3646601.....	23	3665030.....	22	3876946.....	82	36501208		FC-4C-06120-N.....	28	FC-6BG-021C.....	45
3646610.....	23	3665120.....	22	3877060.....	82	36501208.....	21	FC-4C-06120-R.....	27	FC-6BG-022S.....	45
3646611.....	23	3665130.....	22	3877160.....	82	36501240.....	21	FC-4CS-02120-N.....	26	FC-6BG-031C.....	45
3646660.....	23	3809934.....	96	3877260.....	82	36503208.....	21	FC-4CS-02120-R.....	26	FC-6BG-031S.....	45
3646661.....	23	3870146.....	84	3877346.....	83	36503240.....	21	FC-4CS-03120-N.....	26	FC-6BG-032S.....	45
3646666.....	23	3870146A.....	84	3877446.....	83	36504208.....	21	FC-4CS-03120-R.....	26	FC-6BG-041C.....	45
3646680.....	23	3870246.....	84	3877546.....	83	36504240.....	21	FC-4CS-04120-N.....	26	FC-6BG-041S.....	45
3646681.....	23	3870246A.....	84	3877660.....	83	36504240.....	21	FC-4CS-04120-R.....	26	FC-6BG-042S.....	45
3646701.....	23	3870346.....	84	3877760.....	83	36505208.....	21	FC-4CS-04120-T.....	19	FC-6BG-051C.....	45
3646710.....	23	3870346A.....	84	3877860.....	83	36505240.....	21	FC-4DH-01120-I.....	19	FC-6BG-051S.....	45
3646711.....	23	3870460.....	84	3892646		36506208.....	21	FC-4DH-01120-T.....	19	FC-6BG-052S.....	45
3646760.....	23	3870560.....	84	3892646.....	84	36506240.....	21	FC-4DH-01208-I.....	19	FC-6BG-061C.....	45
3646761.....	23	3870660.....	84	3892746.....	84	270280114-2.....	76	FC-4DH-01208-T.....	19	FC-6BG-061S.....	45
3646780.....	23	3870746.....	82	3892846.....	84	270290114-2.....	76	FC-4DH-02120-I.....	19	FC-6BG-062S.....	45
3646781.....	23	3870846.....	82	3893060.....	84	270300114-2.....	76	FC-4DH-02120-T.....	19	FC-6DV-36.....	32
3647110.....	23	3870846.....	82	3893160.....	84	270310114-2.....	76	FC-4DH-02208-I.....	19	FC-6HC-01120-AD.....	29
3647160.....	23	3870946.....	82	3893260.....	84	C		FC-4DH-02208-T.....	19	FC-6HC-01208-AD.....	29
3647180.....	23	3871060		3893546.....	82	C1VW.....	39	FC-4DH-03120-I.....	19	FC-6HC-02120.....	29
3647210.....	23	3871060.....	82	3893646.....	82	CADJ-1.....	39	FC-4DH-03120-T.....	19	FC-6HC-02120-AD.....	29
3647250.....	23	3871160.....	82	3893746.....	82	CADJ-2.....	39	FC-4DH-04208-I.....	19	FC-6HC-02208.....	29
3647260.....	23	3871260.....	82	3894560.....	82	CADJ-3.....	39	FC-4DH-04208-T.....	19	FC-6HC-02208-AD.....	29
3647270.....	23	3871346.....	83	3894660.....	82	CADJ-4.....	39	FC-4DH-05208-I.....	19	FC-6HC-03120.....	29
3647280.....	23	3871446.....	83	3894760.....	82	CB98626.....	43	FC-4DH-05208-T.....	19	FC-6HC-03120-AD.....	29
3647310.....	23	3871546.....	83	3895046.....	83	CB98627.....	43	FC-4DH-06208-I.....	19	FC-6HC-03208.....	29
3647350.....	23	3871660.....	83	3895146.....	83	CB98628.....	43	FC-4DH-06208-T.....	19	FC-6HC-03208-AD.....	29
3647360.....	23	3871760.....	83	3895246.....	83	CB98633.....	43	FC-4HS-24120-BKF.....	50	FC-6HC-04208.....	29
3647370.....	23	3871860.....	83	3896060.....	83	CB98634.....	43	FC-4HS-24120-BKR.....	50	FC-6HC-04208-AD.....	29
3647380.....	23	3872460.....	84	3896160.....	83	CB98635.....	43	FC-4HS-24120-SSF.....	50	FC-6IH-01120.....	15
3647410.....	24	3872460A.....	84	3896260.....	83	CB98636.....	43	FC-4HS-24120-SSR.....	50	FC-6IH-01208.....	15
3647450.....	24	3872560.....	84	5950145.....	31	CB98637.....	43	FC-4HS-30120-BKF.....	50	FC-6IH-02120.....	15
3647460.....	24	3872560A.....	84	5950170.....	31	CB98638.....	43	FC-4HS-30120-BKR.....	50	FC-6IH-02208.....	15
3647470.....	24	3872660.....	84	6958301.....	30	CB98639.....	43				
3647480.....	24	3872660A.....	84								

ITEM.....PAGE	ITEM.....PAGE	ITEM.....PAGE	ITEM.....PAGE	ITEM.....PAGE	ITEM.....PAGE	ITEM.....PAGE
FC-6IH-03120.....15	N	R38718.....81	R39962.....81	SS-6BG-021S.....45	T39728.....80	
FC-6IH-03208.....15	N36300.....74	R38733.....81	R3871346.....81	SS-6BG-022S.....45	T39728A.....80	
FC-6IH-04208.....15	N36301.....74	R38733A.....81	R3871446.....81	SS-6BG-031C.....45	T39729.....80	
FC-6IH-05208.....15	N36302.....74	R38734.....81	R3871546.....81	SS-6BG-031S.....45	T39729A.....80	
FC-6IH-06208.....15	N36303.....74	R38734A.....81	R3871660.....81	SS-6BG-032S.....45	T39730.....80	
FMDL-2V.....40	N36337.....74	R38735.....81	R3871760.....81	SS-6BG-041C.....45	T39730A.....80	
FMDL-3H.....40	N36339.....74	R38735A.....81	R3871860.....81	SS-6BG-041S.....45	T39731.....80	
FMDL-3V.....40	N36341.....74	R38736.....81	R3873346.....81	SS-6BG-042S.....45	T39731A.....80	
FMF-2.....40	N36343.....74	R38736A.....81	R3873346A.....81	SS-6BG-051C.....45	T39732.....80	
FMF-3.....40	N36361.....74	R38737.....81	R3873446.....81	SS-6BG-051S.....45	T39732A.....80	
FMHVN1.....40, 41	N36363.....74	R38737A.....81	R3873446A.....81	SS-6BG-052S.....45	T39767.....80	
FML-1.....40	N36371.....74	R38738.....81	R3873546.....81	SS-6BG-061C.....45	T39768.....80	
FML-2.....40	N36373.....74	R38738A.....81	R3873546A.....81	SS-6BG-061S.....45	T39769.....80	
FML-2V.....40	N37310.....74	R38773.....81	R3873660.....81	SS-6BG-062S.....45	T39770.....80	
FML-3.....40	N37311.....74	R38774.....81	R3873660A.....81		T39771.....80	
FML-3V.....40	N37312.....74	R38775.....81	R3873760.....81	T	T39772.....80	
FML-4V.....40	N37313.....74	R38776.....81	R3873760A.....81	T38707.....80	T39935.....80	
FML-4VS.....40	N98607.....74	R38777.....81	R3873860.....81	T38708.....80	T39936.....80	
FMN-1.....40	N9860206.....74	R38778.....81	R3873860A.....81	T38709.....80	T39937.....80	
FMS-3.....40	N9861006.....74	R38950.....81	R3877346.....81	T38710.....80	T39945.....80	
FMS-4.....40		R38951.....81	R3877446.....81	T38711.....80	T39947.....80	
FMS-5.....40	P	R38952.....81	R3877546.....81	T38712.....80	T39948.....80	
FMS-6.....40	PB89260.....42	R38960.....81	R3877660.....81	T38727.....80	T3870746.....80	
FMS-7.....40	PB89261.....42	R38961.....81	R3877760.....81	T38727A.....80	T3870846.....80	
FMT-1.....40	PB89262.....42	R38962.....81	R3877860.....81	T38728.....80	T3870946.....80	
	PB89263.....42	R39713.....81	R3895046.....81	T38728A.....80	T3871060.....80	
I	PB89264.....42	R39714.....81	R3895146.....81	T38729.....80	T3871160.....80	
INC-80.....39	PB89265.....42	R39715.....81	R3895246.....81	T38729A.....80	T3871260.....80	
INC-80S18.....39	PB89266.....42	R39716.....81	R3896060.....81	T38730.....80	T3872746.....80	
	PB89267.....42	R39717.....81	R3896160.....81	T38730A.....80	T3872746A.....80	
K	PB89268.....42	R39718.....81	R3896260.....81	T38731.....80	T3872846.....80	
K1410-C.....37	PB89269.....42	R39733.....81		T38731A.....80	T3872846A.....80	
K1410-CP.....37	PB89270.....42	R39733A.....81	S	T38732.....80	T3872946.....80	
K1410CS.....37	PB89271.....42	R39734.....81	SS-4PT-36.....91	T38732A.....80	T3872946A.....80	
K1554-C.....36	PB89272.....42	R39734A.....81	SS-4PT-48.....91	T38767.....80	T3873060.....80	
K1734-C.....36	PB89273.....42	R39735.....81	SS-4PT-60.....91	T38768.....80	T3873060A.....80	
	PB89274.....42	R39735A.....81	SS-4PT-72.....91	T38769.....80	T3873160.....80	
L	PB89280.....42	R39736.....81	SS-4PT-84.....91	T38770.....80	T3873160A.....80	
LS03IB.....38	PB89281.....42	R39736A.....81	SS-4PT-96.....91	T38771.....80	T3873260.....80	
LS03IS18B.....38	PB89282.....42	R39737.....81	SS-4PT-108.....91	T38772.....80	T3873260A.....80	
LS03IVB.....38	PB89283.....42	R39737A.....81	SS-4PT-120.....91	T38935.....80	T3876746.....80	
LS03MS18B.....38	PB89284.....42	R39738.....81	SS-4PT-132.....91	T38936.....80	T3876846.....80	
LS03MVS18B.....38	PB89285.....42	R39738A.....81	SS-4PT-144.....91	T38937.....80	T3876946.....80	
LS03PB.....38	PB89286.....42	R39773.....81	SS-4WT-36.....90, 92	T38945.....80	T3877060.....80	
LS03PS18B.....38	PB89287.....42	R39774.....81	SS-4WT-48.....90, 92	T38946.....80	T3877160.....80	
LS03PVB.....38	PB89288.....42	R39775.....81	SS-4WT-60.....90, 92	T38947.....80	T3877260.....80	
	PB89289.....42	R39776.....81	SS-4WT-72.....90, 92	T39707.....80	T3893546.....80	
M		R39777.....81	SS-4WT-84.....90, 92	T39708.....80	T3893646.....80	
MB-1.....41	R	R39778.....81	SS-4WT-96.....90, 92	T39709.....80	T3893746.....80	
MS-2A.....41	R38713.....81	R39950.....81	SS-4WT-108.....90, 92	T39710.....80	T3894560.....80	
MT-1.....41	R38714.....81	R39951.....81	SS-4WT-120.....90, 92	T39711.....80	T3894660.....80	
MT-1.5.....41	R38715.....81	R39952.....81	SS-4WT-132.....90, 92	T39712.....80	T3894760.....80	
MT-2.....41	R38716.....81	R39959.....81	SS-4WT-144.....90, 92	T39727.....80		
MTS-1.....41	R38717.....81	R39961.....81	SS-6BG-021C.....45	T39727A.....80		
MW-1.....41						



TO VIEW
WARRANTY POLICY

**2024
CATALOG**

Note: In the interest of continued product improvement, Vollrath reserves the right to change specifications without notice. Prices and availability also subject to change without notice. Dimensions listed in catalog are approximate and may vary. Contact your Vollrath representative for specific drawing details.

WANT MORE VOLLRATH?

For more than 150 years, Vollrath products have redefined what good kitchen equipment should be. The secret? Provide the customer with what they need before they even need it. That's innovation, and innovation is what separates an industry leader like Vollrath from the competition. Explore our massive product collection to bring out your culinary best, or create tasteful frozen treats your customers will love with Stoelting® frozen treat equipment.



Smallwares

Steam Table Pans & Accessories



Cookware & Bakeware



Kitchen Essentials



Buffet & Tabletop Service



Warewashing & Handling



Dispensing Solutions



Food Delivery



Countertop Equipment

Food Preparation Equipment



Cooking Equipment



Warming Equipment



Merchandising & Display Solutions



Cold Beverage Equipment



Stoelting® Frozen Treat Equipment

Soft Serve & Frozen Yogurt



Shakes & Smoothie Freezers



Frozen Custard & Italian Ice Machines



Frozen Beverage Dispensers



Batch Equipment



Frozen Treat Equipment Cleaning



Accessories





STAY CONNECTED
& INFORMED

Ask a question, get assistance,
request support, or just say hello.

VOLLRATHFOODSERVICE.COM

Customer Service: 800-628-0830

Technical Support: 800-628-0832



VOLLRATH[®]



VOLLRATH®

SERVING SYSTEMS & COMPONENTS

FABRICATOR COMPONENTS

SERVING SYSTEMS

VOLLRATHFOODSERVICE.COM

The Vollrath Company, L.L.C.
1236 North 18th Street
Sheboygan, WI 53081-3201

Main Tel: 920-457-4851
Fax: 800-752-5620 or
920-459-6573

Customer Service: 800-628-0830
Credit: 920-459-5387
Canada Customer Service: 800-695-8560
Technical Services: 800-628-0832